

All Model 350 Series NOVA Truck Lock™

INSTALLATION PARTS & OWNER'S MANUAL

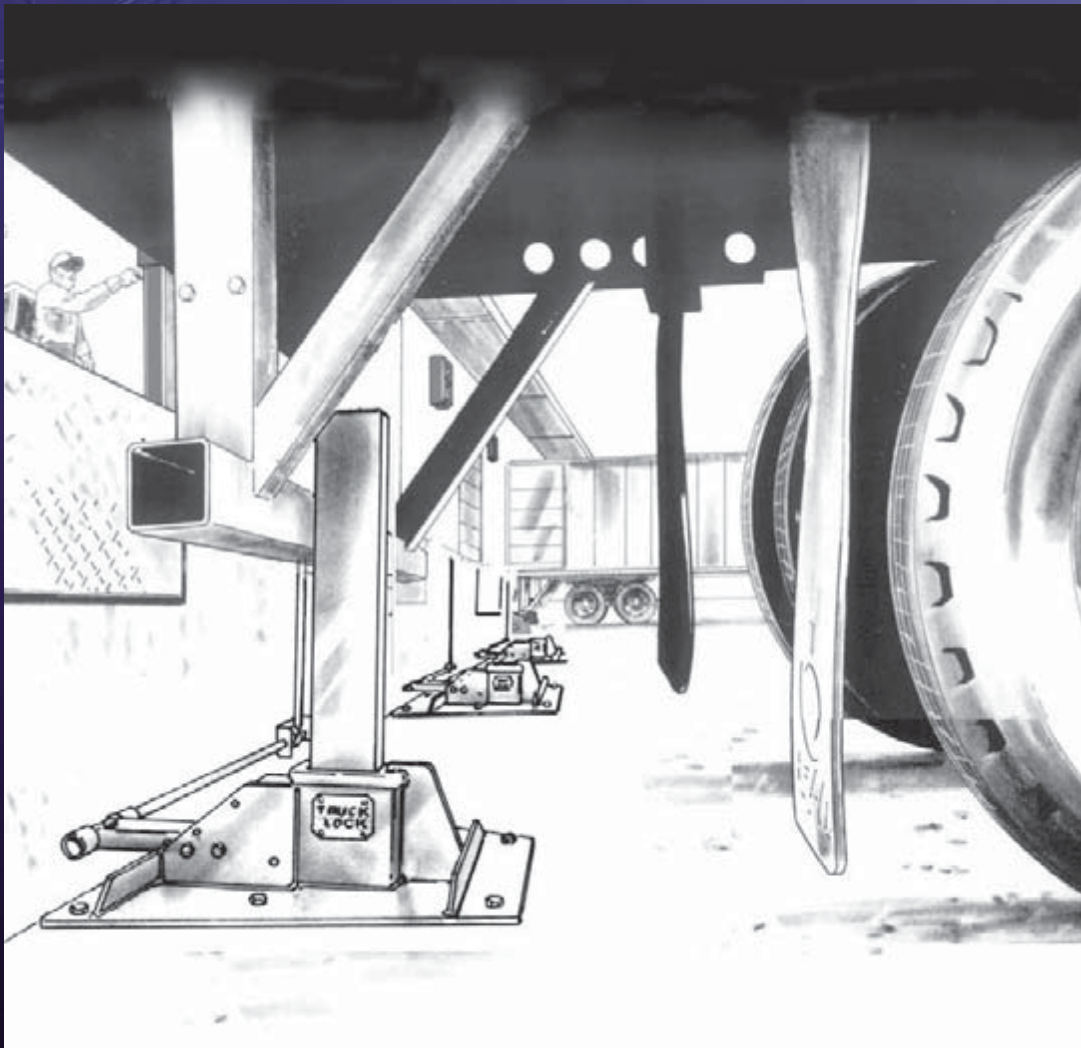

NOVA
TECHNOLOGY™

CATALOG NO. TL3501010

SAFETY WARNINGS:

Lockout/Tagout Procedures

The Occupational Safety and Health Administration (OSHA) requires, in addition to posting safety warnings and barricade the work area (including, but not limited to, trucking office and loading docks), that the power supply and air supply, if applicable, has been locked in the OFF position or disconnected. It is mandatory that an approved lockout device is utilized. The proper lockout procedure requires that the person responsible for the repairs is the only person who has the ability to remove the lockout device.

In addition to the lockout device, it is also a requirement to tag the power control and air control, if applicable, in a manner that will clearly not that repairs are under way and state who is responsible for the lockout condition. Tagout devices have to be constructed and printed so that exposure to weather conditions, or wet and damp locations, will not cause the tag to deteriorate or become unreadable.

Nova Technology does not recommend any particular lockout device, but recommends the utilization of an OSHA approved device and procedures (refer to OSHA regulation 1910.147). Nova Technology also recommends the review and implementation of an entire safety program for the Control of Hazardous Energy (Lockout/Tagout). These regulations are available through OSHA publication 3120.

 **DANGER**

This is the highest level statement. Failure to follow the listed instructions will most likely result in severe injury or death.

 **CAUTION**

The statements used with this level of warning deal with a safe operating procedure. If the procedure is ignored, the possibility of personal injury may exist.

 **WARNING**

This is a statement of serious hazard. Failure to follow the listed instructions could place the individual at risk of serious injury or death.

IMPORTANT

Important is used to draw attention to a procedure that needs to be followed to prevent machine damage.



INTRODUCTION



The NOVA Technology Truck Lock 350™ when properly installed and operated, offers the user substantially improved dock safety and efficiency. Its design is the result of many years of experience with loading dock operation.

It features an easy to read inside light system for the dock attendant, a simple "STOP & GO" outside light system for the truck driver, and a restraining device to discourage premature or unexpected truck departure.

Read and follow all installation and operating instructions. Be certain to read and understand all caution statements in this booklet as well as all warning labels on the equipment. Be sure all dock attendants are properly trained in the system's function and operation.

Perform periodic inspection to insure there are no worn or damaged parts which could result in equipment failure and/or personal injury.

INDEX

INTRODUCTION	PAGE 1
ARRANGEMENT AND FUNCTION OF MAJOR COMPONENTS	PAGE 2
RESTRAINT SEQUENCE	PAGE 3
INSTALLATION INSTRUCTIONS	PAGE 4-16
TOOL LIST	PAGE 17
GENERAL MAINTENANCE	PAGE 18
WIRING DIAGRAM	PAGE 19
ILLUSTRATED PARTS LISTS	PAGE 20-23

WARRANTY

NOVA TECHNOLOGY INT'L, LLC. warrants the NOVA TRUCK LOCK 350™ to be free of defects in material or workmanship under normal use for a period of one year from the date of shipment. This warranty does not cover any failure to properly maintain the product. This warranty is the only one given by NOVA TECHNOLOGY INT'L, LLC. and is in lieu of all guarantees and warranties expressed or implied by anyone other than NOVA TECHNOLOGY INT'L, LLC. including those of fitness for a particular purpose and merchantability. In order for warranty claims to be honored the products must have been properly installed, maintained, and operated within their intended function and not otherwise abused.

If your NOVA TRUCK LOCK 350™ is defective in material or workmanship and you notify NOVA TECHNOLOGY INT'L, LLC. within one year of the date of shipment, NOVA TECHNOLOGY INT'L, LLC. will, at its' option, repair or replace the defective component(s) at no cost to you.

NOVA TECHNOLOGY INT'L, LLC. will not be responsible for or pay for loss of time, inconvenience, loss of the use of the product, or property damage caused by this product or its failure to work, or any other incidental or consequential damages.

NOVA TECHNOLOGY INT'L, LLC. reserves the right to change specifications or make product improvements without notice or obligation.



CAUTION

Be sure that installation is performed only by qualified personnel and that electrical hook-up is performed by a qualified electrician.

HELLO!
THIS IS
IMPORTANT!



THIS IS
NOVA

This view shows typical arrangements and functions of major components for the NOVA 350 Truck Lock™ Series

- Review Distributors' survey sheet
- Verify that the Data Corresponds to your job site requirements

■ **INSIDE LIGHT.** "RED" indicates that it is not safe to enter the truck. "GREEN" indicates that the truck has been restrained.

■ **OUTSIDE TRUCK CONTROL LIGHT.** Shows "GREEN" if truck can safely back in or pull out. Shows "RED" while truck is restrained.

■ **RAM ACTIVATION HANDLE.** Handle in "RELEASED" position — ram is lowered (stored) and outside "GREEN" light is flashing. Handle in "RESTRAINED" position — ram is raised and outside "RED" light is flashing.

■ **MECHANICAL TRUCK RESTRAINT AND HOUSING.**

Ram rises in front of truck's ICC BAR to restrain forward truck movement.

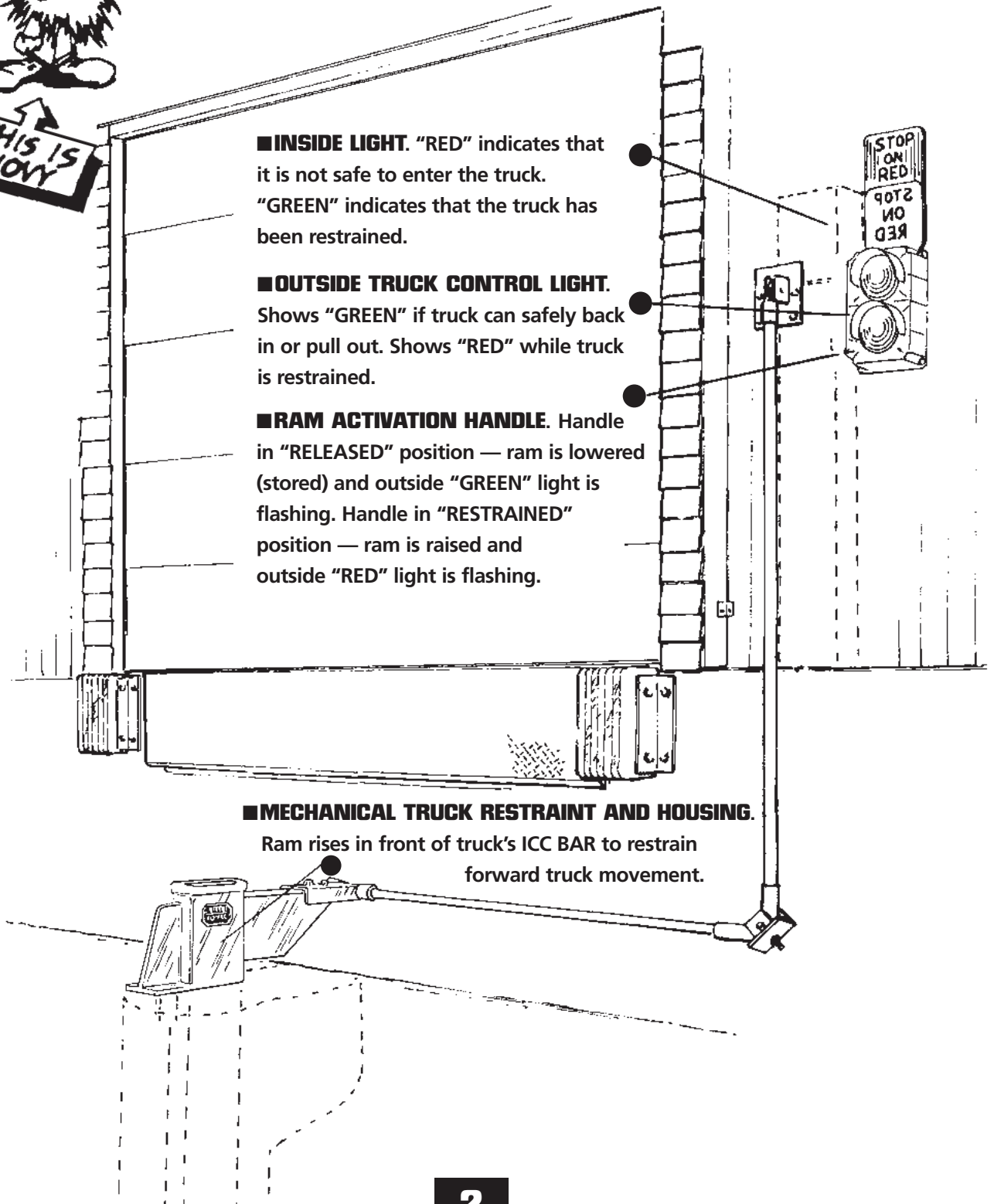

NOVA TRUCK LOCK™ RESTRAINT SEQUENCE

MODELS	ALL	ALL	ALL
CONDITIONS AT LOADING DOCK	RED/GREEN OUTSIDE LIGHTS	RED/GREEN INSIDE LIGHTS	ACTIVATION HANDLE/SWITCH
<ul style="list-style-type: none"> •TRUCK ARRIVES •RAM IS LOWERED 	FLASHING GREEN	FLASHING RED	RELEASED
<ul style="list-style-type: none"> •TRUCK IS IN & RESTRAINED LOADING/ UNLOADING •RAM IS RAISED 	FLASHING RED	CONSTANT GREEN *	RESTRAINED
<ul style="list-style-type: none"> •TRUCK IS IN & LOADING/ UNLOADING IS COMPLETED •RAM IS LOWERED 	FLASHING GREEN	FLASHING RED	RELEASED

*If ram's upper movement is restricted by a bent ICC bar or other obstruction, the outside "Red" light will flash indicating to the truck driver that it is not safe to pull out. Inside, the Audible Alarm will sound and both inside lights will flash alternately warning the dock attendant that an alternate method for restraining the vehicle is needed.

Pressing the Silence button will silence the alarm and the interior lights will continue to flash alternately. Once loading or unloading is complete, the dock attendant will depress and hold the silence button to reset the outside light. Once the truck has left the dock, it is necessary to completely cycle the restraint to reset all the lights.

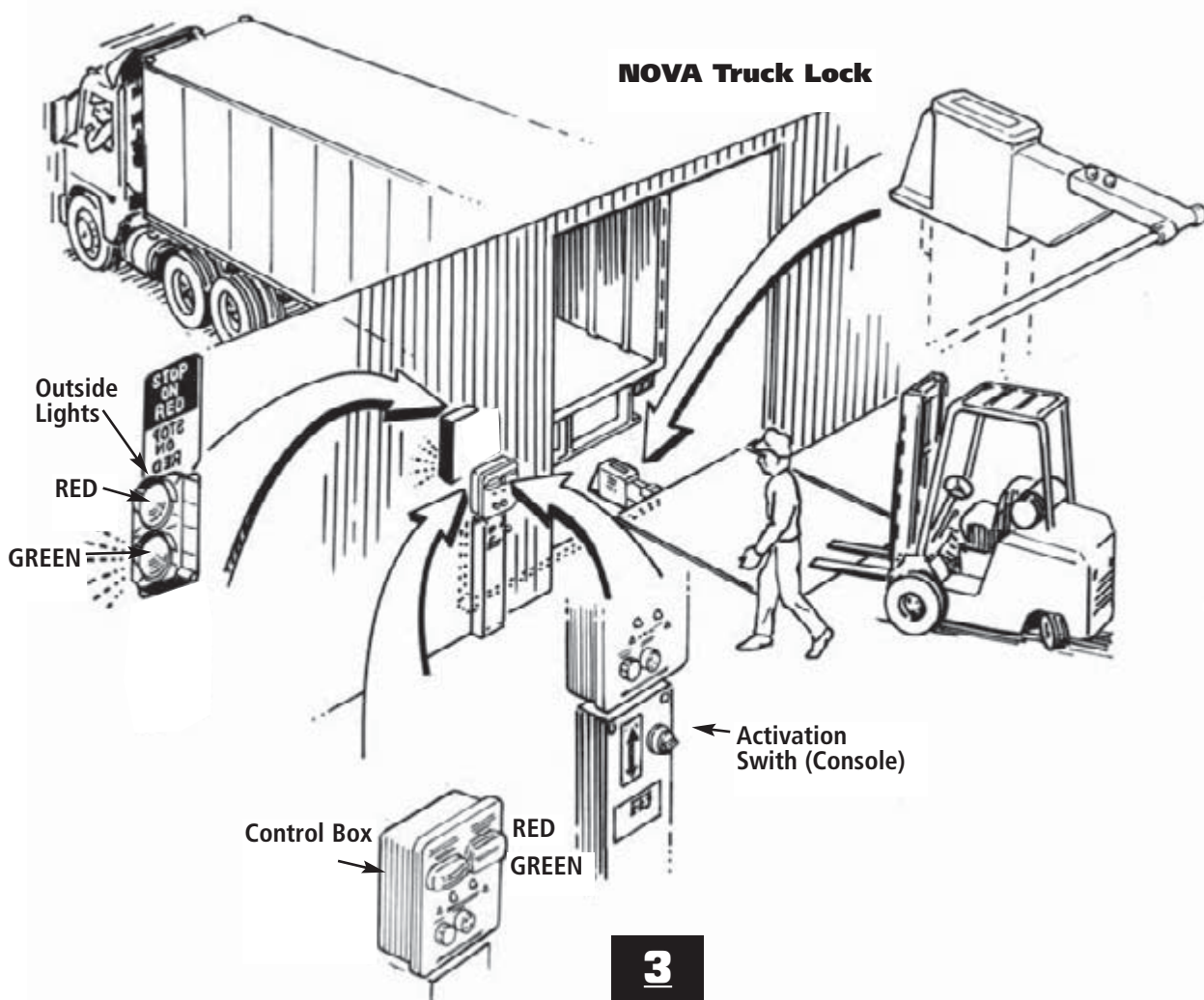

INSTALLATION INSTRUCTIONS

Every installation should be a show piece and potential customer reference.
Please follow these instructions and the info on the survey sheet.

STANDARD SUPPLIES (per unit) furnished by INSTALLER.

- Assorted Concrete Fasteners
- Concrete Mix — approx. 3-8 cu. ft., depending on concrete or asphalt drive.
(Minimum strength 4000 psi)
- 3/4" Thinwall Conduit — 20 ft. (Activation Cable Run)
- 1/2" Thinwall Conduit — 20 ft. (Truck Sensor Run)
- 1/2" Conduit Elbows (Two) (Truck Sensor Run)
- 1/2" Wall Clips (for conduit) (Truck Sensor Run)



Nova Technology requires NOVA Juice-E to be used on all new truck restraints. Failure to follow instructions will result in a voided warranty.

NOTE: If sensor switch kit is purchased, install sensor switch housing prior to pouring concrete

Step 1 For Concrete

- Determine exact location of restraint ram housing per diagram. Figure 1.

NOTE: All dimensions are from face of dock bumpers. If bumpers are not yet installed, add thickness of bumpers.

CAUTION

When unpacking the Nova Lock be careful not to lose parts that are within the specially made packing boxes.

■ Figure 1

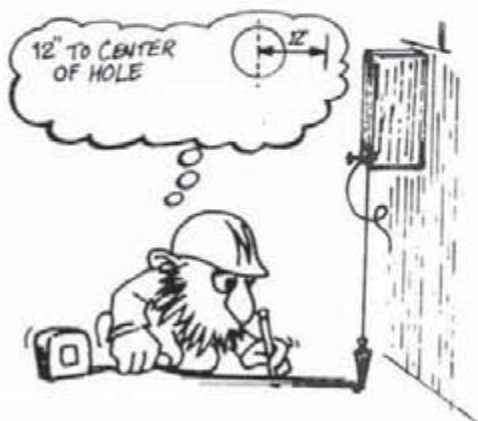
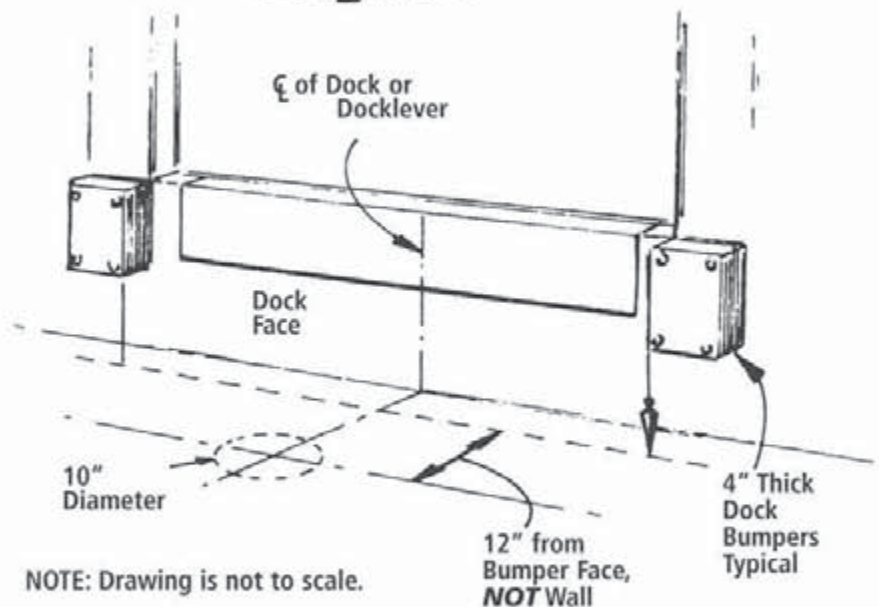

Step 2 For Concrete

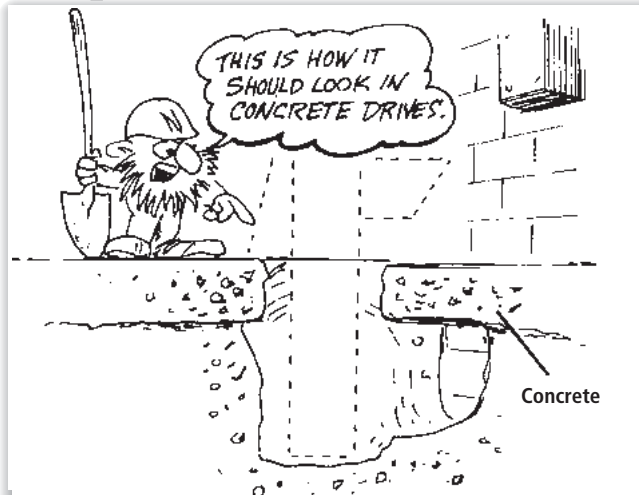

CAUTION

IMPORTANT: Remember Dimension from Back Edge of Ram to Bumper Face should be 10".

■ Core drill (auger, posthole digger, etc.) a 10" diameter hole minimum of 30" deep. The final shape of completed excavation depends on driveway surface.

■ For non-concrete driveway surface, an area as shown must be cut out. This yields a much more substantial base since asphalt is subject to some movement climatically. See Figure 3 for placement of rebars when installing in non-concrete drive.

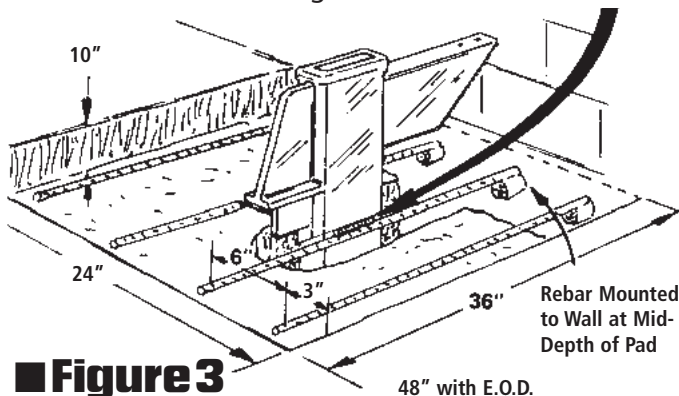

■ **Figure 3**

48" with E.O.D.

Step 3

■ Support housing in augered hole and secure with concrete. See figure 2.

NOTE: Ram housing must be "plumb" in all directions and bottom of front support must be flush with top of drive. If installing in unfinished driveway, be sure to install at finished drive height. If new driveway is other than concrete, please refer to Figure 3 for pad dimensions.

WARNING

Concrete should have minimum compressive strength of 4000 PSI or equivalent.

IMPORTANT

Front support must be in full contact with the poured concrete.

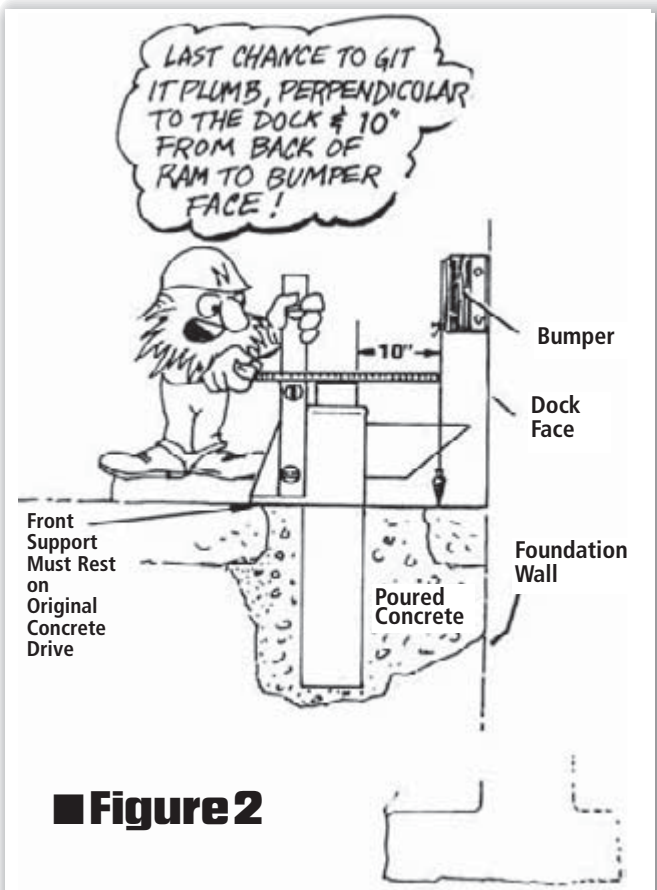

■ **Figure 2**

NOTE: Housing may be welded to the middle two rebars to help hold and stabilize Housing during concrete pour.

■ **While the concrete is setting up, you now can proceed with the mounting of brackets and console.**

IMPORTANT

Be sure there are no obstructions on outside of building which would interfere with cable run between control console and ram housing. Position control console so that activation cable clears dock bumpers. Also be sure that there is adequate clearance for future installation of dock seals or shelters. See Figure 4.



WARNING

Prior to installation of actuation cable, make sure concrete has set-up, or else cable force may loosen housing in concrete.

Step 4

■ Remove cover from control console by removing four 3/8"x1/2" bolts. See Figure 5.

If metal building support is required as per survey sheet, follow those instructions for correct installation. Also remove remote box cover plate before removing (2) 1/4-20x1, nuts, flat washer, star washer.

Step 5

■ Temporarily place control console (with cover removed) against inside wall in desired location. Mark the four mounting holes for the console (two on wall and two on floor) as well as the 1" diameter cable exit hole. See Figure 6.



WARNING

■ **WARNING!** GET THIS PART RIGHT TO AVOID CABLE RUBBING BETWEEN PULLEYS.

1. CABLE MUST RUN ON PULLEYS.
2. CABLE MUST RUN LINE OF SIGHT BETWEEN PULLEYS.
3. CABLE MUST NOT RUB ON WALL MATERIAL.

Step 6

■ First, drill the 1" diameter cable exit hole through the wall from the inside at the location marked in Figure 6.

Replace bracket and check alignment of the 1" hole per Figure 6 — then drill mounting holes.

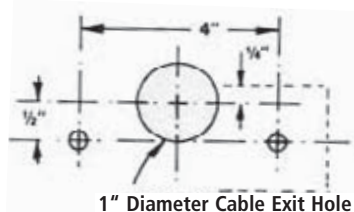

Step 7

■ Mount control console on inside of building wall.

NOTE:

Use expansion bolts, toggle bolts or through bolts as appropriate. Bolts and fasteners supplied by installer.

Figure 4

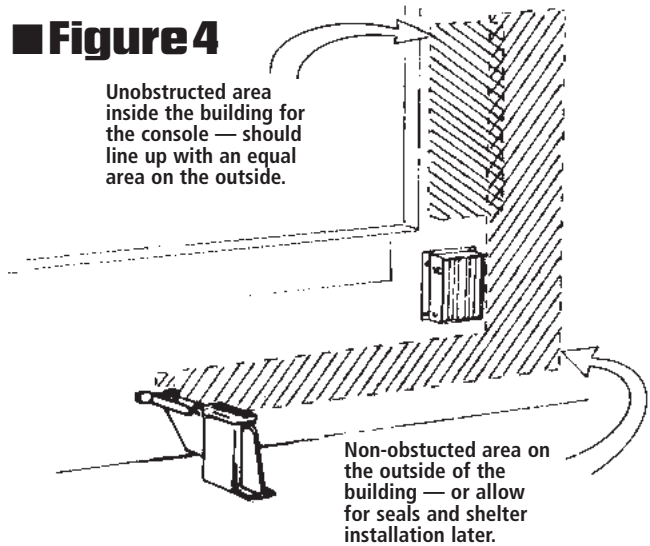

Figure 5

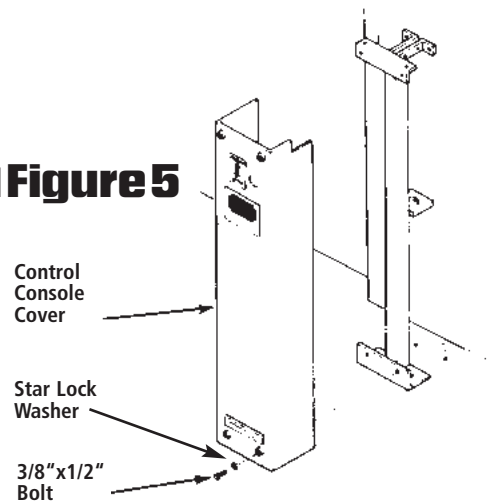
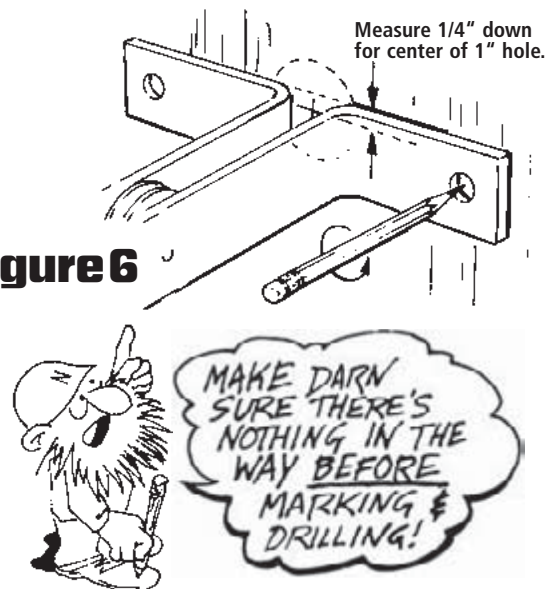

Figure 6



NOTE:

To prevent outside concrete wall from chipping, drill a 1/2" pilot hole first. If into a block wall, loose insulation, etc., sleeve the hole with a section of 3/4" conduit.

Step 8

■ Mount upper outside pulley to exterior wall, being sure top of pulley aligns with center of 1" hole through wall. See Figure 7. Installer supplied anchors.

NOTE:

Recessed building wall or dock foundation wall may require a special bracket as per your survey sheet.

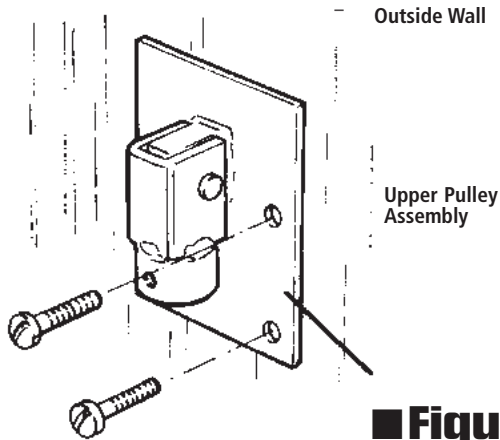

■ **Figure 7**

Step 9

■ Mount lower pulley swivel assembly to foundation directly beneath upper pulley assembly. Installer to supply fasteners.

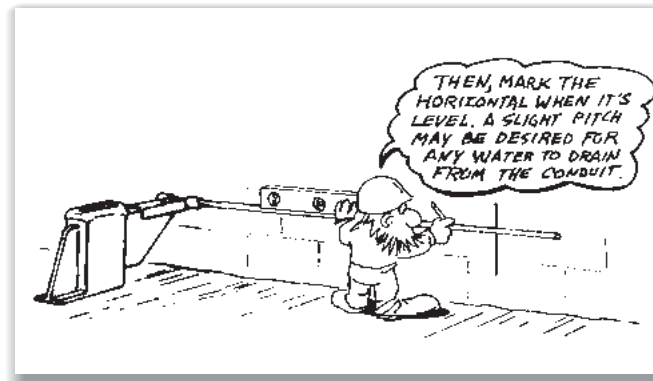
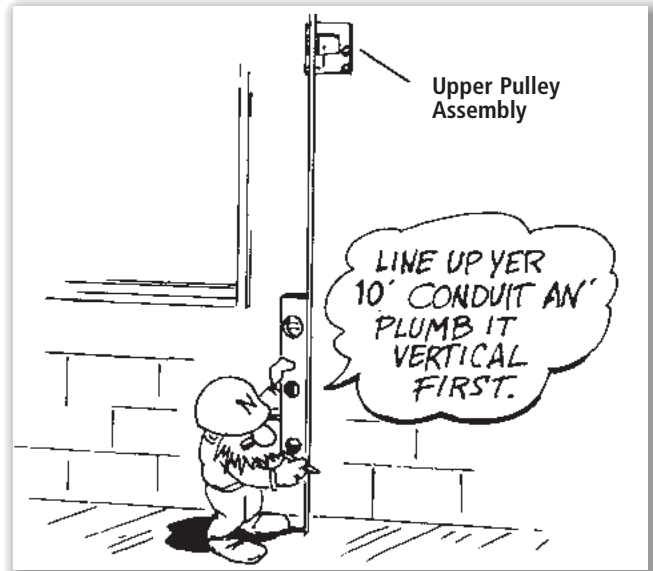
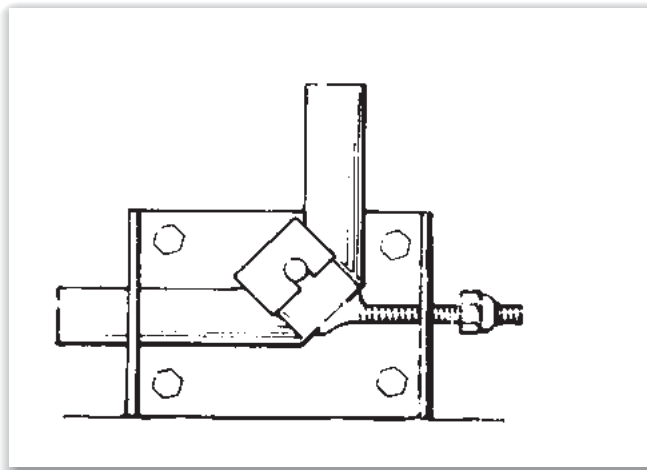

AFTER THE CONCRETE HAS SET-UP

Step 10

■ Figure 8A

IMPORTANT

■ Remove ram from housing and carefully pour in Nova Juice-E. This liquid provides lubrication and prevents freezing under normal conditions. See Figure 8A. Nova Juice-E will fill housing to 9" and provides lubrication.

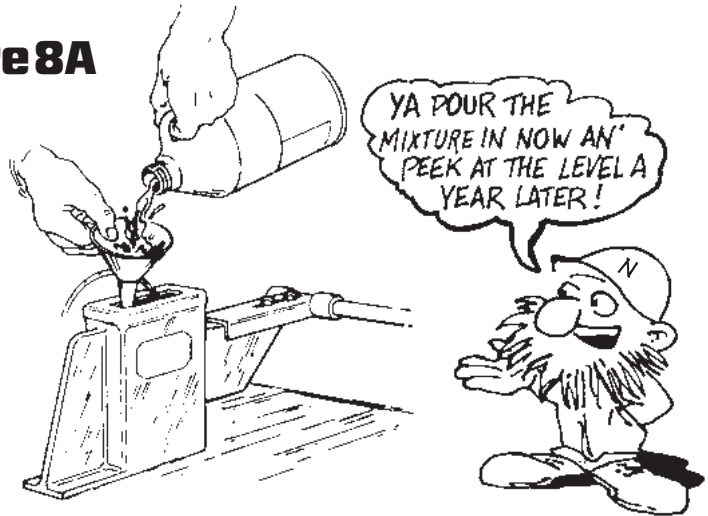

Nova Technology requires NOVA Juice-E to be used on all new truck restraints. Failure to follow instructions will result in a voided warranty.

Step 11

■ Weld or bolt E.O.D. extension bracket as shown in Figure 9. E.O.D. extension bracket should touch building wall face when positioned properly.

■ Figure 9



Step 12

■ Measure distance between conduit collar on upper pulley and conduit collar on lower pulley swivel and add 2-3/4". Cut a piece of 3/4" thin wall conduit to this length. See Figure 10.

Step 13

■ Measure distance from conduit collar on lower pulley to conduit collar on ram housing assembly and add 2-3/4". Cut 3/4" thin wall conduit to length as above. Slide end into tube on lower pulley. Thread cable through lower and upper pulley assemblies.

Allow free cable end to stick out of conduit at top pulley. Do not attempt to feed through building wall at this time. Slide end of conduit into conduit collar on ram housing and secure with set screw. See Figure 10.

■ Figure 10

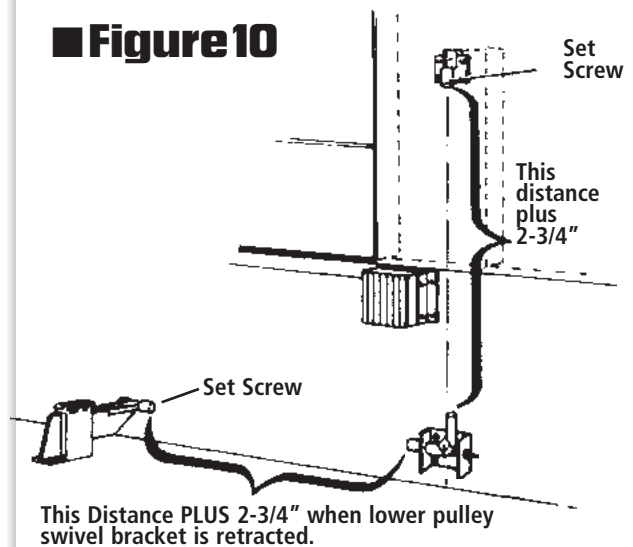

Step 14

■ Route ram cable around top of upper outside pulley, into building through hole in wall, and over the pulley between wall bracket on control console. See Figure 11.

■ Figure 11

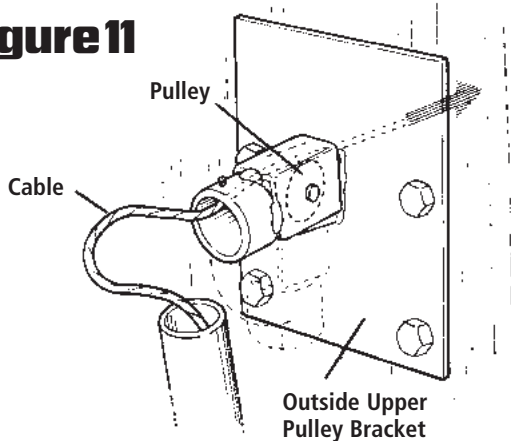

Step 15M

■ **MANUAL RESTRAINTS.** Raise handle to full up position. Make sure upper limit switch lever is contacting Activation Handle Tube. Pull cable tight. Around extension spring, and cable clamp with threads towards slide pole. See Figure 12.

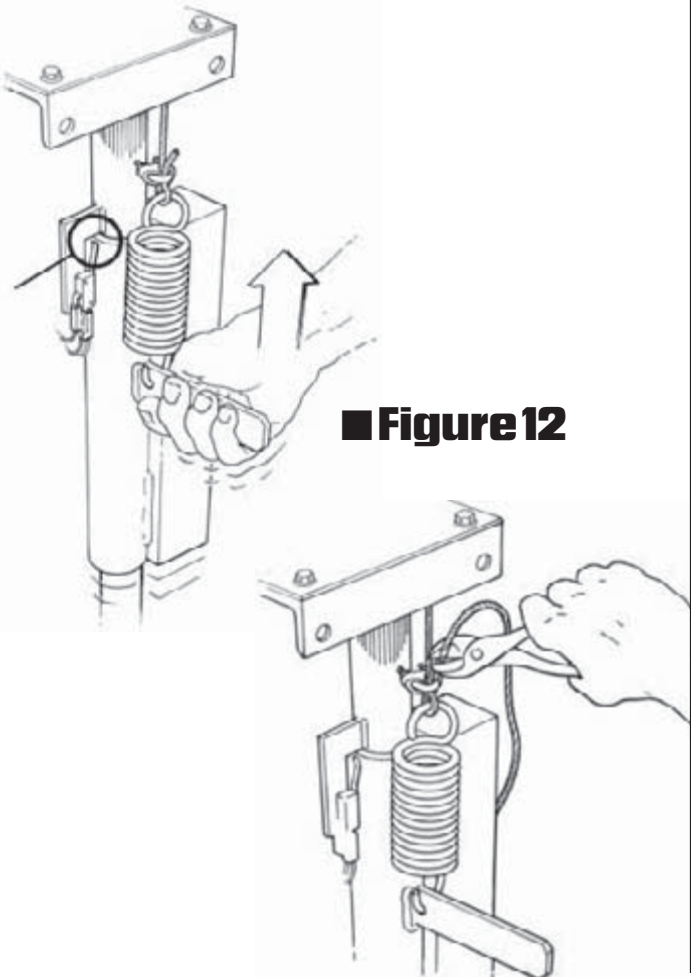

■ Figure 12

Step 15P

■ Manually extend air cylinder. Run end of cable through pulley at top of cylinder rod, pull cable tight, and attach end to clevis pin at top on control console frame using cable clamp supplied. See Figure 13. Cut off excess cable.

IMPORTANT

Pull cable only tight enough to remove all slack from cable. Do not pull so tight that you raise the ram from its resting position in the housing.

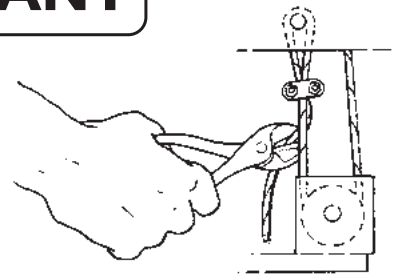

■ Figure 13

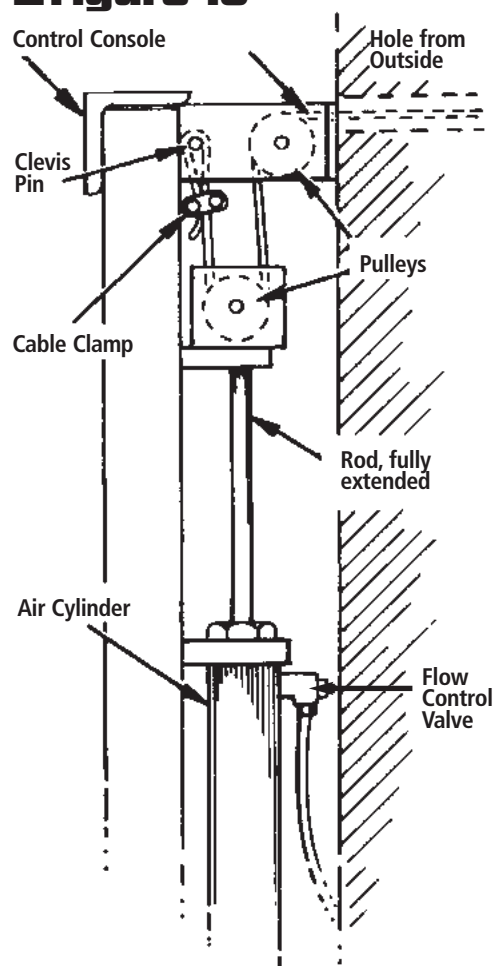

Step 16 For Model 351M and 351P

■ Determine location of outside light on exterior of building. Light must be on truck driver side of dock door (right side when facing dock from outside) and 8' above surface of drive. Be sure location of light will not interfere with the future installation of dock shelters or seals. Drill hole through wall at approximate center of light. Feed wire from light through hole in wall and affix light to wall. See Figure 13MP.

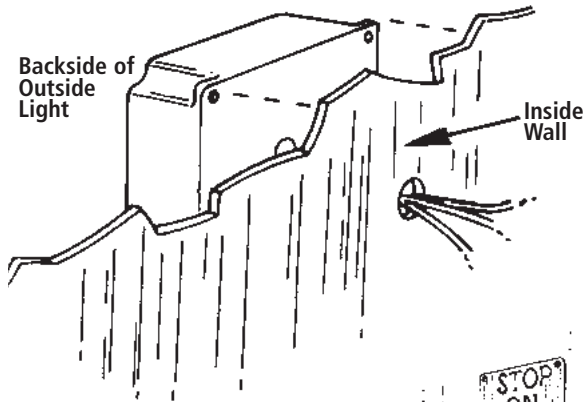

Step 17 For Model 351M & 351P

■ Fasten printed sign to outside wall, above, as shown in Figure 13. "RED" sign should be above light.. Attach sign to building with fasteners.

Figure 13MP

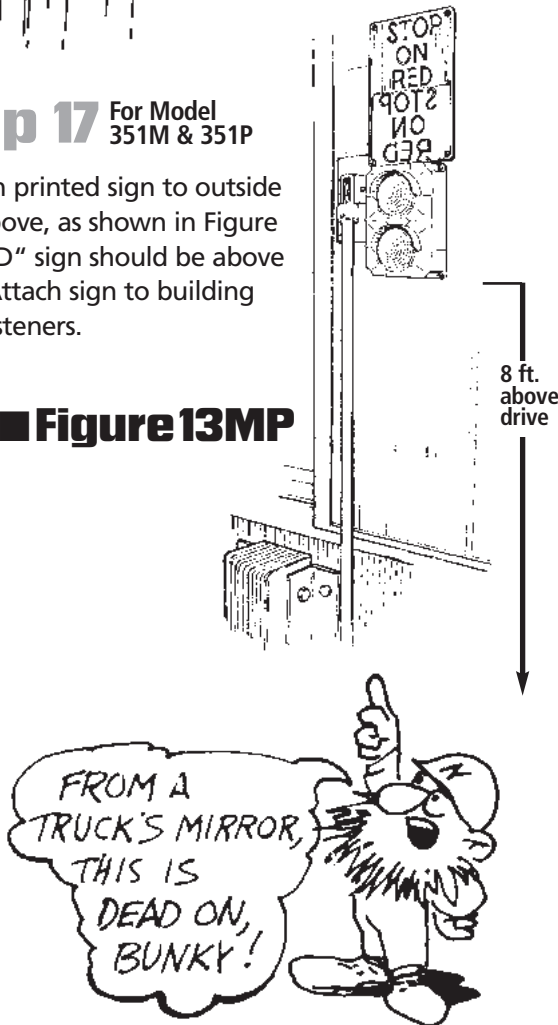

Step 18 For Model 351M and 351P

■ Mount control box to wall 1" to 2" above console using fasteners supplied by installers.

Figure 14

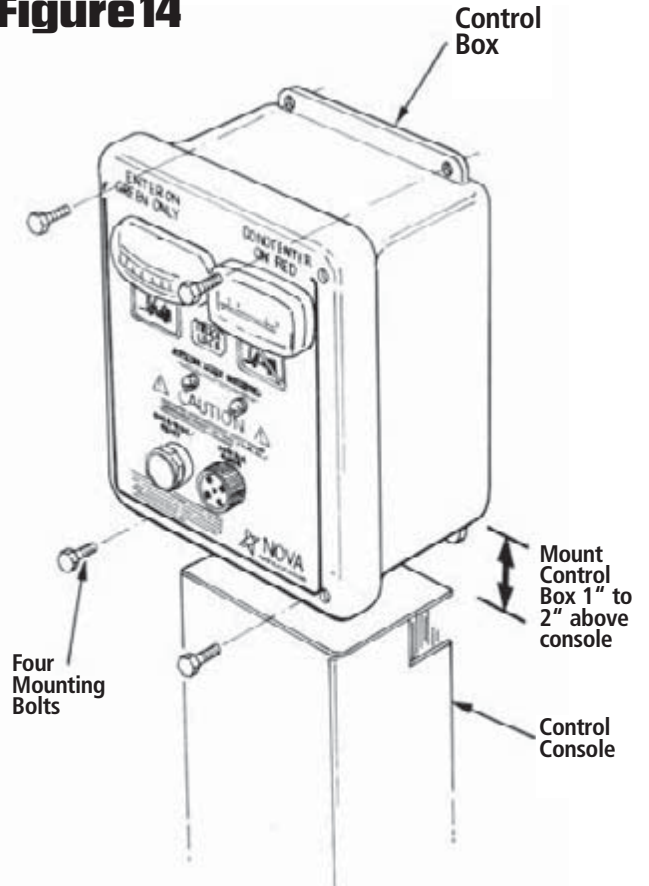

CAUTION

All control and lighting circuits are low voltage. Installation of 115V grounded supply circuit must conform to local electrical codes and customer specifications.

CAUTION

Be sure that installation is performed only by qualified personnel and that electrical hook-up is performed by a qualified electrician.

Step 19M For Model 351M Only

■ Turn console cover around. Connect the (2) three-wire electrical cables from the control box to the limit switches, one mounted on the cover and the other mounted on the top of the slide pole. See Figure 15.

Step 19P For Model 351P Only

■ Connect the (2) three-wire electrical cables from the control box to the limit switches mounted on the console frame. See Figure 14P.

Figure 14P

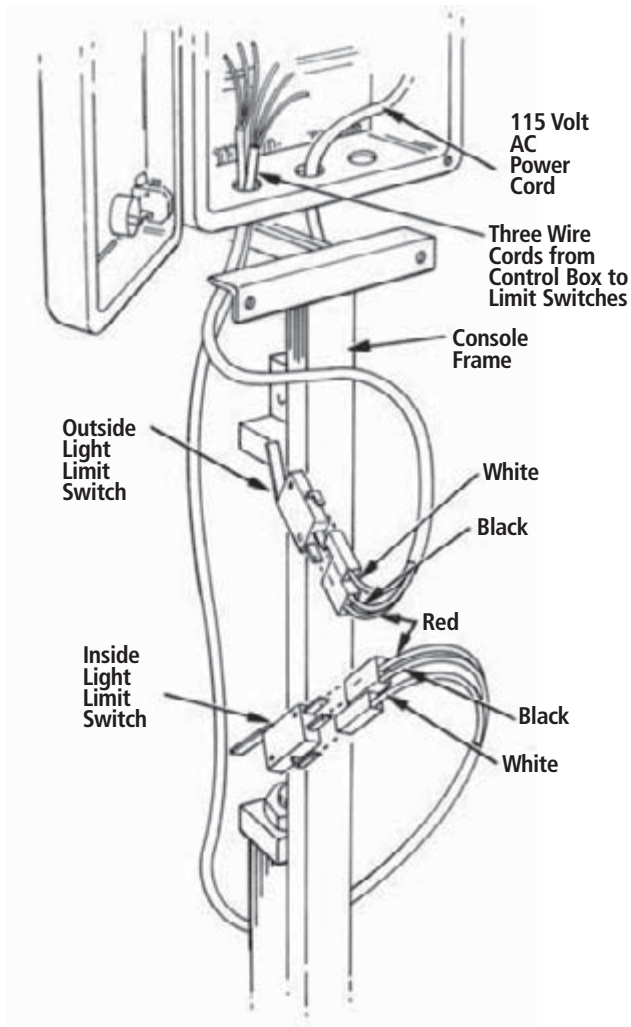
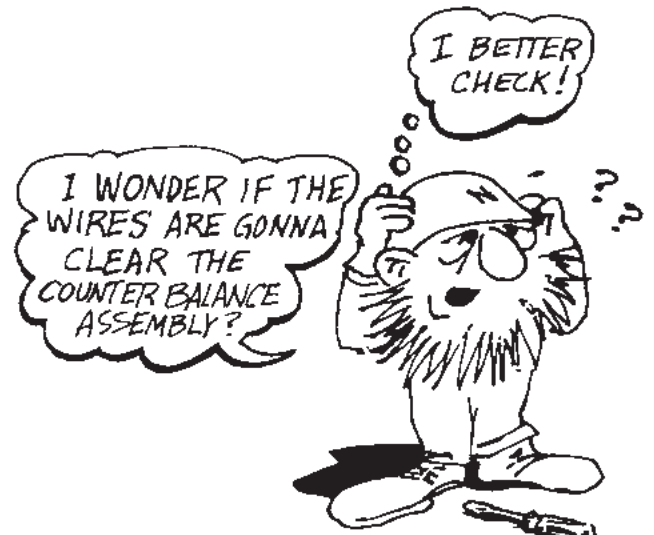
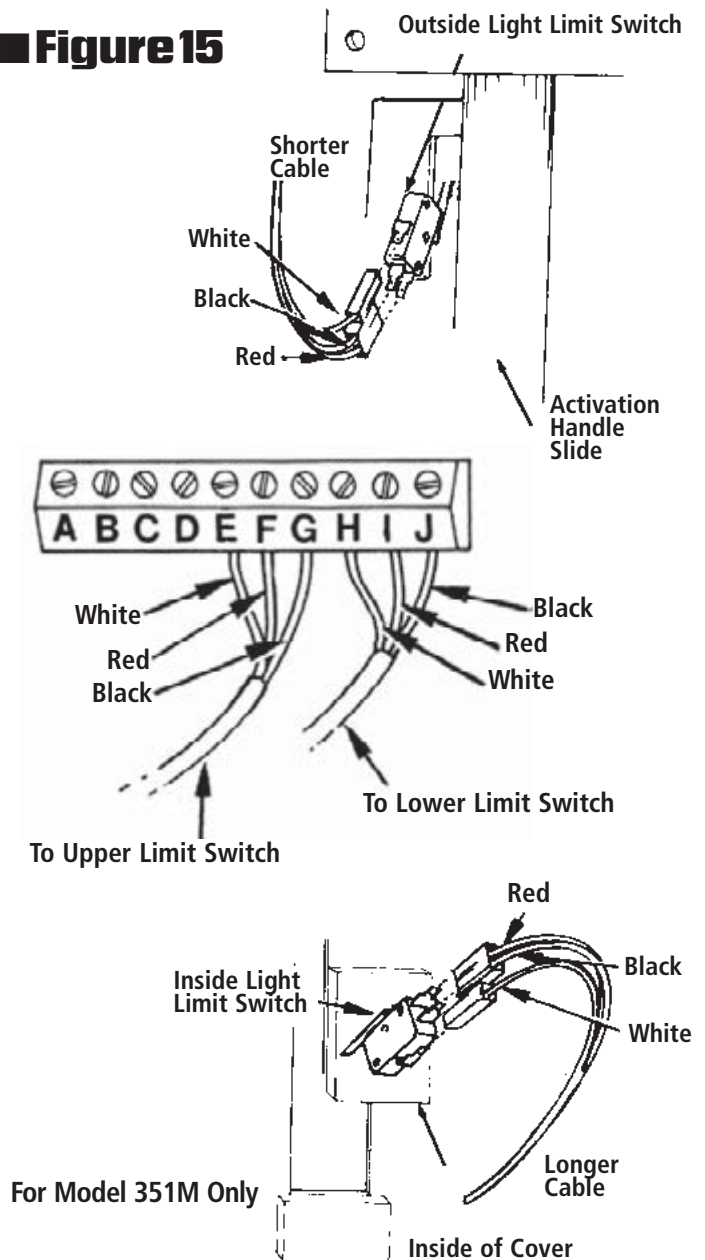

Figure 15



Step 20M For Model 351M & 351P

Figure 16

Route wire from outside light to inside control box through the grommets hole in the bottom of the box. Cut to length and connect to terminal strip as shown in Figure 16.

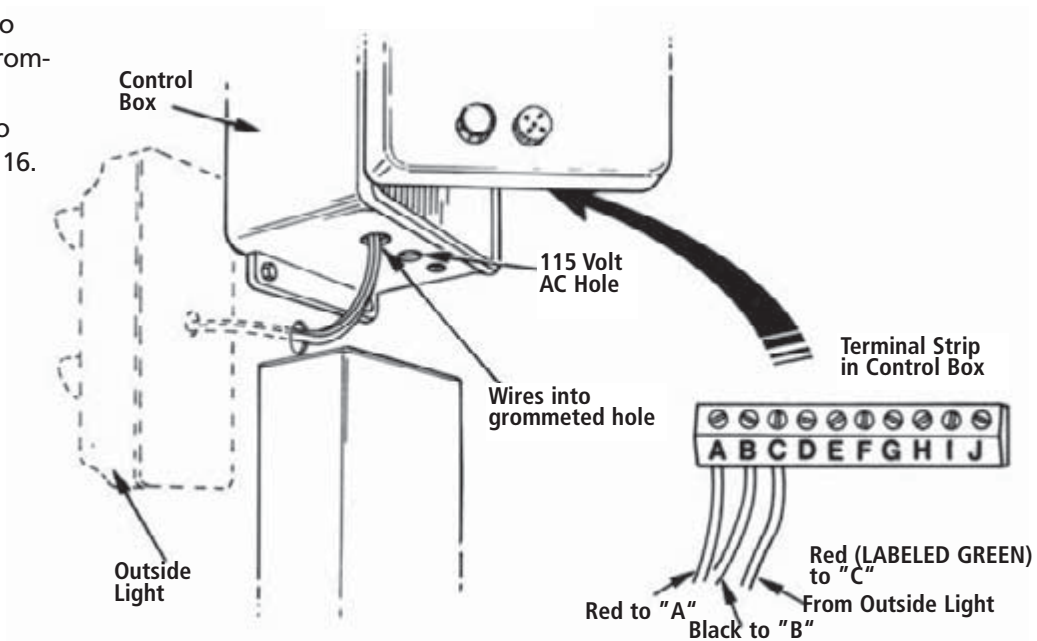

Step 21M

■ Replace cover on control console and secure with four 3/8"x1/2" bolts and star lock washers. Slide plastic grip on to Activation Handle. See Figure 17.

IMPORTANT

Make sure that wires from control box will not get tangled in activation handle, or counterweight assembly once console cover is replaced

■ Figure 17

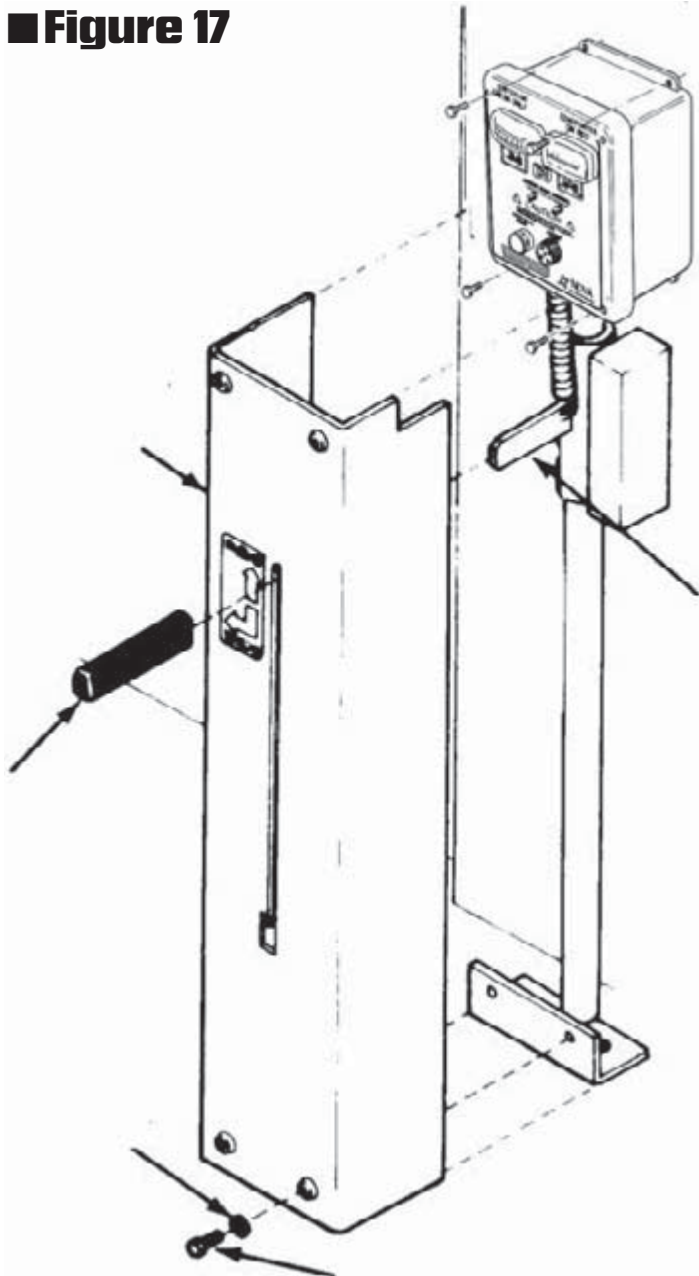

Step 22M

■ Move Activation Handle down into "Restrain" position which will raise restraint ram outside. Adjust ram height by turning nut on lower pulley assembly. Tighten cable until entire hole in ram is visible above top of ram housing. Do not overtighten as ram will not completely lower when handle is raised. See Figure 18.

■ Figure 18

Lower Pulley Swivel Assembly

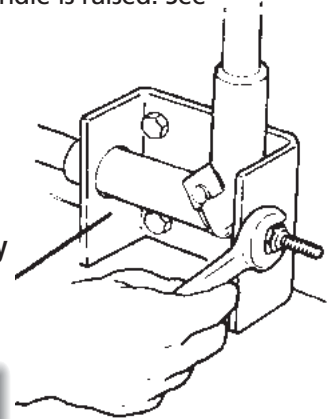

Entire Guide Height Hole in Ram is Visible

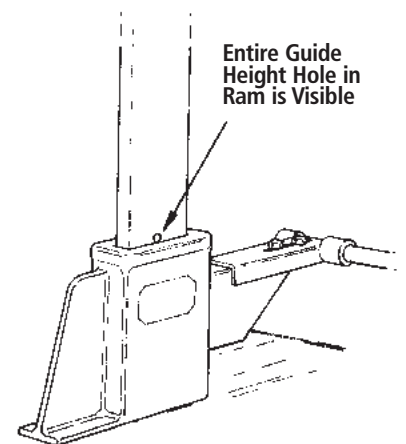

Step 23M

■ Test entire sequence as outlined in Operating Instructions on Page 3.

This completes the installation of a typical Manual System — turn to page 15 for important final checks

NOTE: Air may be supplied from plant system or by small compressor. Air must be minimum of 80 lbs./square inch and maximum of 130 lbs./square inch. Air must be dry and clean. Air usage is approximately .015 cubic feet per operation. Duration of normal power stroke is about 2 seconds.

Step 21P

■ Run 1/4" polyurethane tubing capable of withstanding 150 psi above dock doors as in Figure 19. Plot the tees to align with the console(s).

■ Figure 19

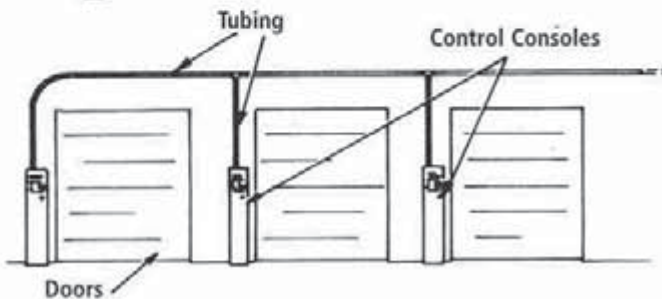

Step 22P

■ Run polyurethane tubing from header tee to control valve. Cut polyurethane tubing to allow for cover removal.

Step 23P

■ Connect short tube from control valve to flow control on air cylinder. See Figure 20.

■ Figure 20

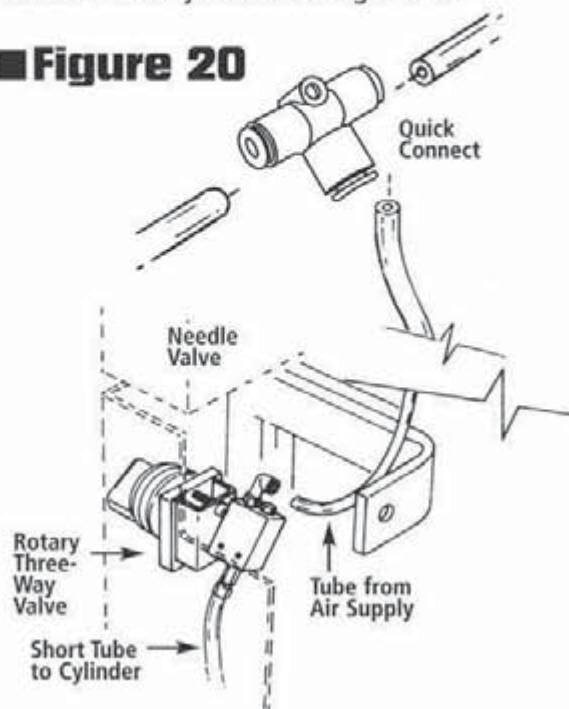

Step 24P

■ Turn air supply on.

⚠ CAUTION

Be sure to keep hands clear of air cylinder, pulley assembly and cable when retracting cylinder. Personal injury could result.

Step 25P

■ Rotate selector valve knob to up "RESTRAIN" position.

NOTE: The unit is shipped with the needle valve 4 turns open.

Step 26P

■ Rotate selector lever to down and lower ram.

NOTE: Lowering speed is not adjustable and is controlled by internal orifice.

Step 27P

■ Cycle unit again. Turn adjusting knob on flow control valve out to increase rise speed and in to decrease speed. Continue to cycle unit until desired speed is obtained.

NOTE: When properly adjusted, the ram should fully rise in 1 to 2 seconds. There should be less than 1/2" of "hop" by the ram at the end of the rise stroke.

⚠ CAUTION

Adjusting flow control valve so that ram rises too fast can cause unnecessary stress on the unit and may present danger to personnel or equipment.



Step 28P

■ Replace control console cover and secure with four 3/8" x 1/2" bolts and star lock washers.

Step 29P

■ Move control switch to "RESTRAINED" position. Adjust ram height by turning nut on lower pulley assembly. Tighten cable until entire guide height hole in ram is visible above top of ram housing. Cycle unit several times to check cable adjustment. See Figure 21.

⚠ CAUTION

If Ram does not completely lower, cylinder damage could result and range of Truck Lock will be reduced.

■ Figure 21

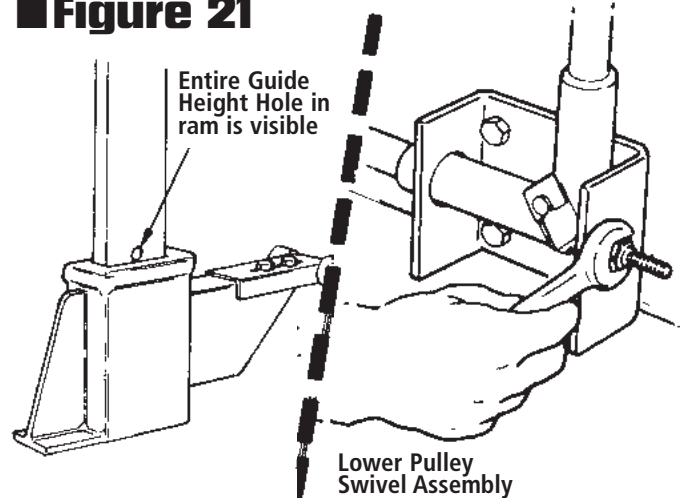

This completes the installation of a typical pneumatic system, see below for important final checks.

IMPORTANT CHECKS!

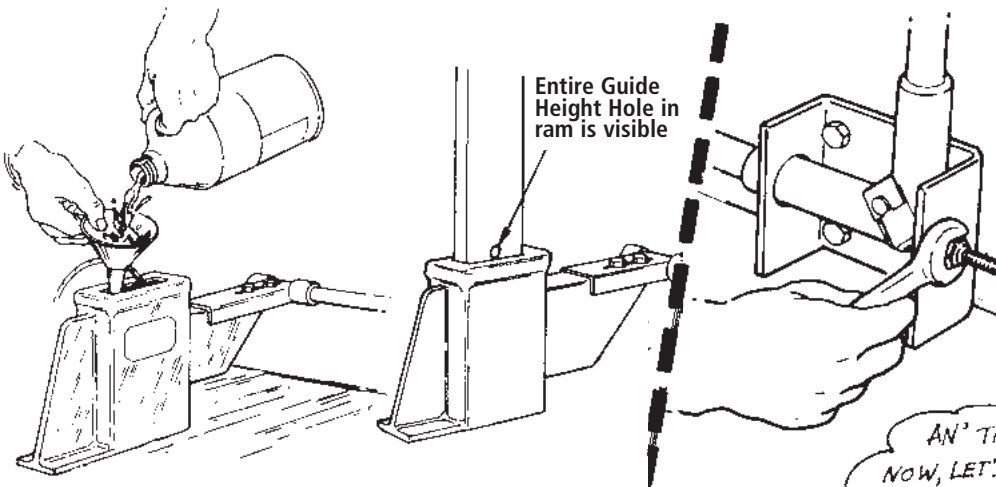

Adjust cable length by turning nut on lower pulley assembly. Tighten cable until entire guide height hole in ram is visible above top of ram housing. Do not over-tighten as ram will not completely lower when switch is released.



Nova Technology requires NOVA Juice-E to be used on all new truck restraints. Failure to follow instructions will result in a voided warranty.



Steps 1S & 2S applies only to Sensor Switch Kit

Step 1S Sensor Switch Kit Only

■(For Model 351P only). Install 1/2" thinwall conduit to shield sensor switch wire running to control box as shown in Figure 23.

Step 2S Sensor Switch Kit Only

■Uncoil wire from sensor switch and feed through conduit to control box and through grommited hole. Cut wire to length and connect to terminal strip as shown in Figure 22.

■ Figure 22

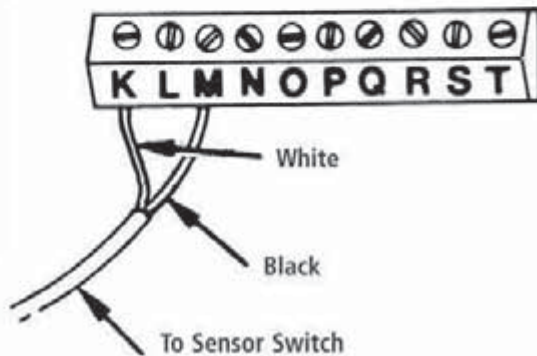

■ Figure 23

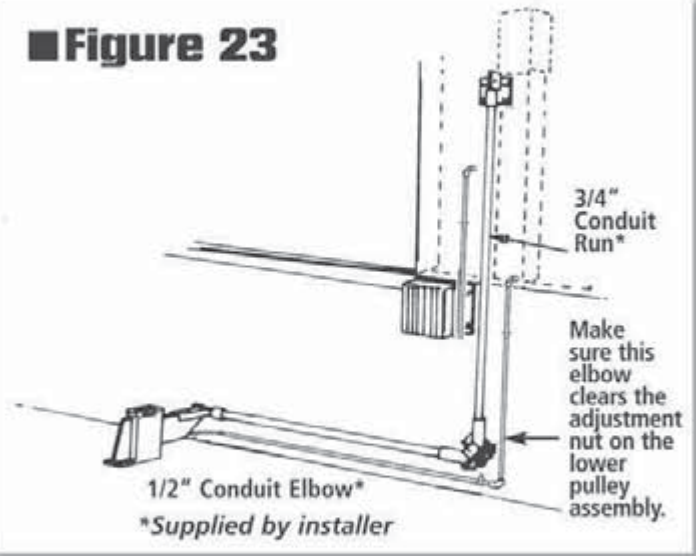

Steps 1 IC-3 IC applies only to Model 351P w/Interconnect

Step 1 IC

■Mount the limit switch under the dock board as shown in Figure 24. (Limit switch may also be used in conjunction with the overhead door.)

■ Figure 24

Switch is mounted in such a manner so that when dock lip is at a 45° angle, switch should click and system is activated.

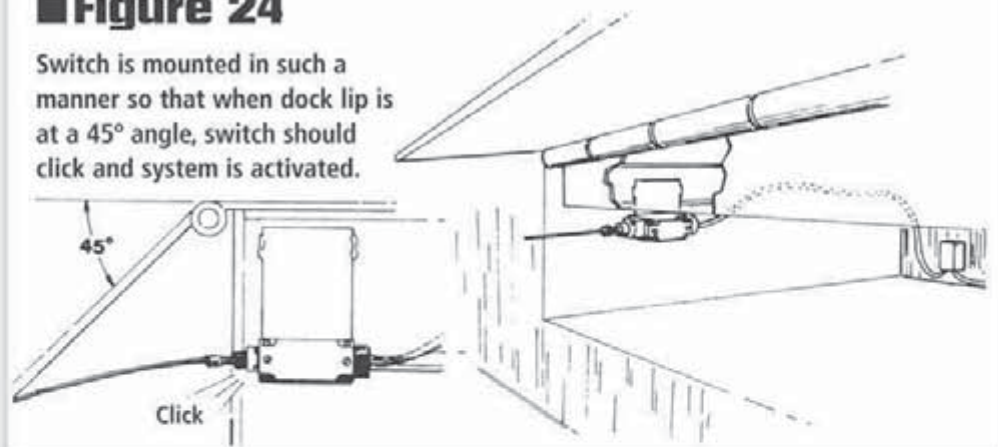

Step 2 IC

■Route wire from limit switch into control box through the grommited hole. Cut the wire to length and connect to the terminal strip as shown in Figure 33. Black to "Q", Red to "R".

Step 3 IC

■Route wire from solenoid valve into control box through the grommited hole. Cut the wire to length and connect to the terminal strip as shown in Figure 33. Black to "S", Black to "T". (Either black wire in either position will work.)

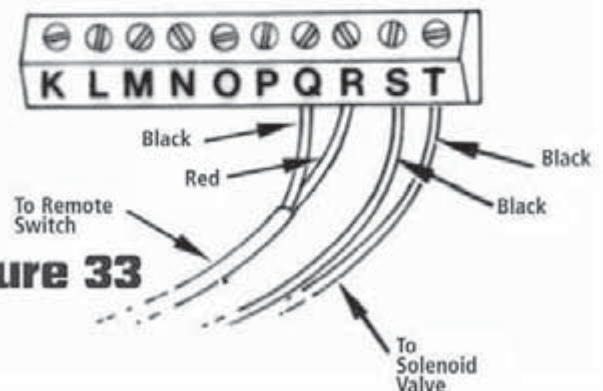

■ Figure 33

TOOLS LIST

SUGGESTED TOOLS AND SUPPLIES for installing and servicing Nova Truck Locks

Utility Knife
Tape Measure
Chalk or Marker for marking hole locations
120 Volt Power Source
Core Drill with water for coolant
10" Ø Core Bit
(2) 12" extensions for Core Bit
Post hole digger or auger to clean out hole
Rock Bar/Pry Bar and shovel
Torch to cut metal in the hole
Rotary Hammer Drill
5/8" x 12-16" long masonry bit (Flange Anchors)
1" x 12" long masonry bit (hole for cable)
1/2" x 6" long masonry bit (Outside Mount Angle)
Impact Wrench-torque capabilities of 75 ft-lbs with 3/4" and 15/16" impact sockets
Cement, water and mixer, wheelbarrow, pail (for Cast in place units)
Ram rod to agitate the concrete
Trowels to finish off the concrete
Hammer
1/2" Drill/Hammer drill
1/4" x 6" long masonry bit (Wall Brackets)
3/8" x 6" long masonry bit (Console Support, Console Feet and top, Control Box Mount, Outside Console Mount)
1/2" x 6" long masonry bit (Console Angle-Outside Mount Only)
Wrenches 3/8", 7/16", 1/2" 9/16", 3/4", 15/16",
Sockets- 3/8", 7/16", 1/2" 9/16", 3/4", 15/16",
Nut Driver-3/8"
Allen Wrenches 1/8", 5/32" ball end
Adjustable Crescent Wrench. Up to 1"
(2) 10' sticks of 3/4" thin wall Conduit
Level
Conduit/ Pipe cutter
File to clean burr after conduit is cut
6-8' stepladder
Funnel
Mini flat, Small, Medium and Large Screwdrivers Flat and Phillips
Side Cutter for cable
Duct Tape
Channel locks
Welder
Chrome Paint
Shim stock
(2) 10' sticks of 1/2" thin wall conduit (for Sensor Switch option)
5/16" transfer punch (for Sensor Switch option)
1/8" HSS twist drill bit (for Sensor Switch option)
3/8" square socket adaptor for drill (for Sensor Switch option)
3/8" socket with 3/8" drive (for Sensor Switch option)
Electrical Junction Box (for leveler interconnect option)

Concrete Anchors
(8) to (20) 1/4" or 5/16" x 2" long Nail Pin Anchors (Wall Brackets, Control Box)
(12) to (31) 3/8 x 3-1/2 or 4" long Stud style anchors (Console Support,
Console Feet, Control Box Mount, Outside Console Mount, Open Dock Stanchion)
(5) 1/2" x4" long stud style anchors (outside mount option only)

Other Fasteners
1/4-20 x 1" Hex Head Bolts
1/4-20 Hex Nuts
1/4" washers and lock washers
3/16" washers
1/4 x1-1/4", 5/16 x 1-1/4", and 3/8 x 1-1/4" lag screws (for drywall or wood interior walls)
1/4-14 x 1 tek screws

FOR SERVICING RESTRAINTS

The following tools are suggested in addition to the above:
Shop-Vac with a conduit adaptor to replace fluids in housing
Grease with applicator
Step drill or cone drill 1-3/16" Ø for valve replacement
Multi-meter for checking control Box
Wire stripper
Wire
Duct Tape

SUGGESTED SUPPLIES TO CARRY ON TRUCK WHEN SERVICING:

Cables
Light bulbs (Outside, Inside, LED) and lenses
Pulleys 1", 1-3/4", 2"
Nova Juice-E
Rotary Valve
Cylinder Ass'y 10" and 12"
Limit Switches
Sensor Switch Ass'y
Wands for limit switches

GENERAL MAINTENANCE

⚠ WARNING

Be sure that main power to unit is locked out and tagged according to OSHA regulations and local codes prior to performing any maintenance or repair!

Daily

■ Operate the TRUCK LOCK to assure it is in proper working condition. Replace damaged or missing light bulbs and lenses.

Every 180 Days

■ Apply grease to slide pole or cylinder pole.

Annually

■ **ALL MODELS.** For best performance, remove old, used fluids (siphon, drill pump, shop vac) and replace with new mixture. Replace all outside light bulbs.



Nova Technology requires NOVA Juice-E to be used on all new truck restraints. Failure to follow instructions will result in a voided warranty.

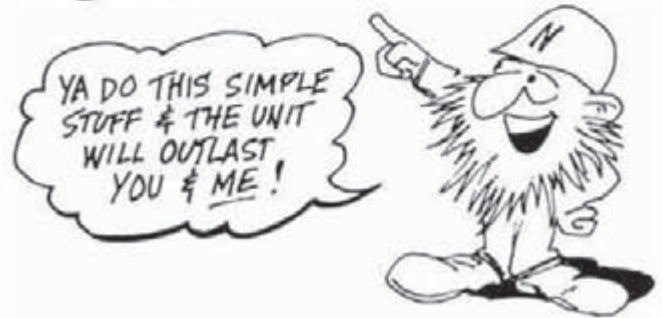

ELECTRICAL TROUBLESHOOTING

■ **NOTE:** In case of electrical malfunction, refer to electrical troubleshooting guide as well as the wiring diagram.

⚠ WARNING

Be sure that the main power to the unit is locked out and tagged according to OSHA regulations and local codes prior to performing any electrical work. Electrical troubleshooting and repair should be performed only by a qualified electrician.

Light Functions and Related Components

LIGHT MALFUNCTION	RELATED COMPONENTS
All	115V power to unit, fuse, transformer, upper and lower limit switch.
Outside Red	L.E.D., upper limit switch.
Outside Green	L.E.D., upper limit switch.
Both Outside Lights	Common lead to lights, upper limit switch.
Inside Red (Flashing)	L.E.D., lower limit switch.
Inside Red (Constant)	L.E.D., lower limit switch.

LIGHT MALFUNCTION	RELATED COMPONENTS
Inside Green	L.E.D., lower limit switch.
Blue (Flashing)	L.E.D., lower limit switch, sensor switch.
Blue (Constant)	L.E.D., lower limit switch, sensor switch.
All Inside Lights	Common lead to lights (cover), lower limit switch.

Electrical Component Check

COMPONENT	CHECK
Fuse	Visual and continuity.
Printed Circuit Board	Visual check L.E.D. on Board.

COMPONENT	CHECK
Transformer	Disconnect and check primary continuity and secondary continuity.
Limit Switches	Disconnect and check continuity. common/normally open, common/normally closed

Truck Lock™ 351 Series Electrical Schematic

Term	Component	Wire Color	QD	Component	Wire Color / #
A	Outside Light	Red	QD1	10V Trans	Blue 10VAC
B	Outside Light	Black	QD2	10V Trans	Blue 10VAC
C	Outside Light	Red- Labeled Green	QD3		
D			QD4	Red Light	Blue-1
E	Outside Limit Switch- Upper	White	QD5	Red Light	Blue-3
F	Outside Limit Switch- Upper	Red	QD6	Green Light	Blue-2
G	Outside Limit Switch- Upper	Black	QD7	Green Light	Blue-13
H	Inside Limit Switch-Lower	White	QD8	Alarm Reset	Blue-10
I	Inside Limit Switch-Lower	Red	QD9	Alarm Reset	Blue-11
J	Inside Limit Switch-Lower	Black	QD10	Blue LED	Blue-
K	Sensor Switch	White	QD11	Blue LED	Blue/Wh
L	Sensor Switch	Red	QD12	Red LED	Blue-7
M	Sensor Switch	Black	QD13	Red LED	Blue/Wh-6
N	Interlock Relay	Blue	QD14	Green LED	Blue-4
O	Interlock Relay	Blue	QD15	Green LED	Blue/Wh-5
P					
Q	Remote Switch	Blue	QD16	Sounder	Blue-8
R	Remote Switch	Blue/Red	QD17	Sounder	Blue-9
S	Solenoid Valve	Black	QD18	Selector Switch	Blue-12
T	Solenoid Valve	Black	QD19	Selector Switch	Blue-15
			QD20	Selector Switch	Blue-14
			QD21	24V Trans	Blue 24VAC
			QD22	24V Trans	Blue 24VAC

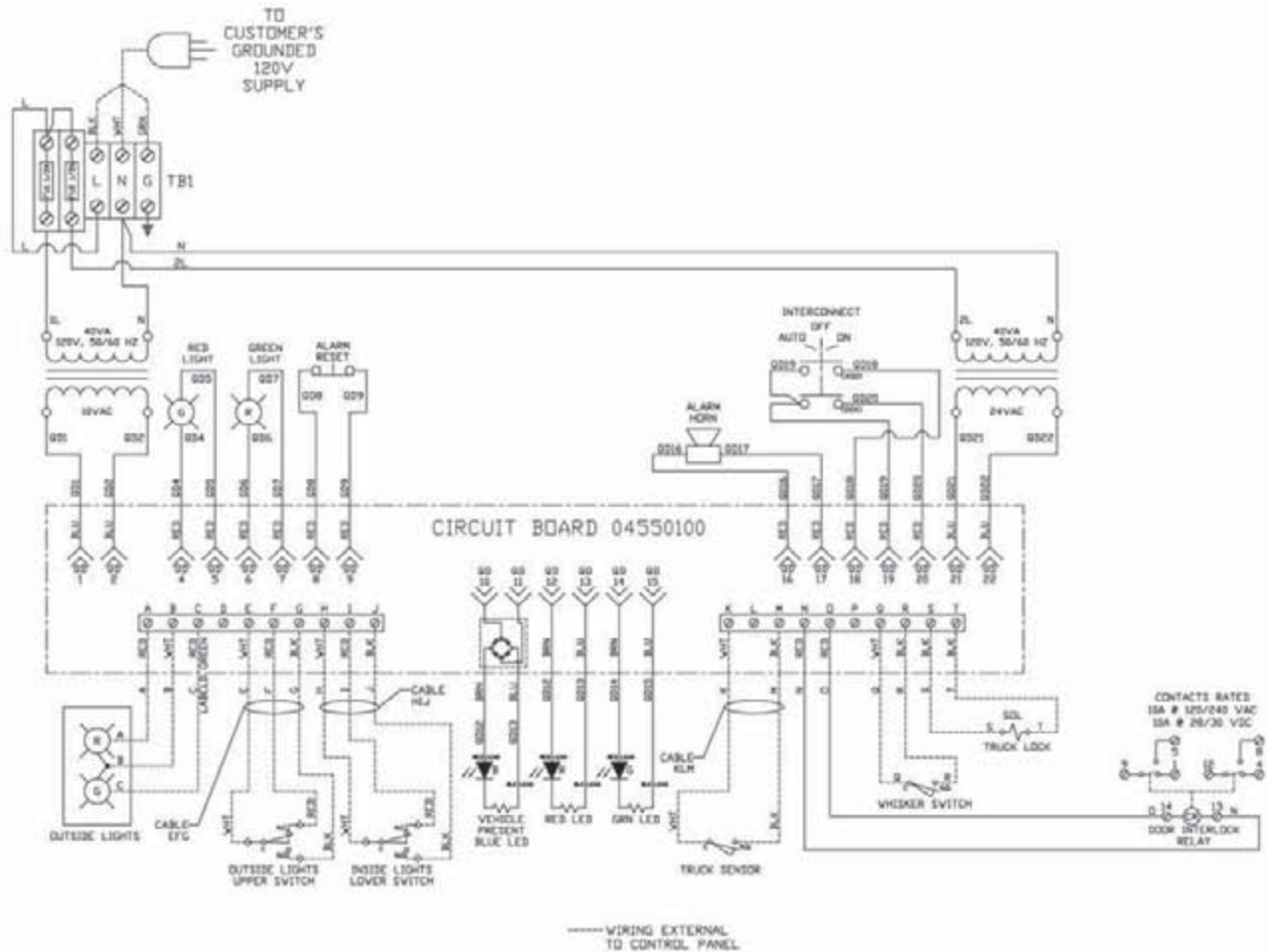

350 Series Ram & Ram Housing Assembly

Models 350M, 351M, 351P

350M, 351M, 351P Ram & Ram Housing Assembly

ITEM	QTY	DESCRIPTION	PART NUMBER
1	1	350 Housing Assembly	35-3-001
2	1	Ram Assembly	31-3-900
3	1	Ram Dampener	31-1-031
4	1	Extension Bracket Long Ass'y	40-3-902
5	1	Extension Bracket Medium Ass'y	40-3-906
6	1	Extension Bracket Short Ass'y	40-3-901
7	2	Socket Set Screw 1/4-20 x 1/4	01-0-007
8	2	Pulley 1-1/4"	03-0-002
9	1	Clevis Pin, Detent, 1"	01-0-018
10	1	350 Housing Pulley Mount Ass'y	35-3-924
11	1	Pulley 2"	03-0-004
12	1	Clevis Pin 3/8 x 1-3/8	02-0-017
13	1	Cotter Pin 1/8 x 3/4	01-0-012
14	1	Flange Nut 3/8-16	01-0-144
15	1	25' Cable	03-0-001
16	2	Housing Plug	01-0-160
17	1	Lower Pulley Swivel Mount	41-1-020
18	1	Lower Pulley Swivel Assembly	41-3-908
19	1	Hex Nut 3/8-16 Nylok	01-0-016
20	1	Clevis Pin 1/4 x 1	01-0-017
21	1	Pulley Cover	31-1-105
22	1	Flange Bolt 3/8-16x1	01-0-122
23	2	Cotter Pin 1/16 x 3/4	01-0-082
24	1	Upper Pulley Swivel Brck Assy.	41-3-912
25	1	Clevis Pin 1/4 x 1-1/4	01-0-083
26	1	Swivel Cap	41-1-902
27	1	Sensor Switch Kit	15-3-001
30	1	Sensor Switch Assembly	06-3-925
31	1	Sensor Spring (Wand)	06-0-065

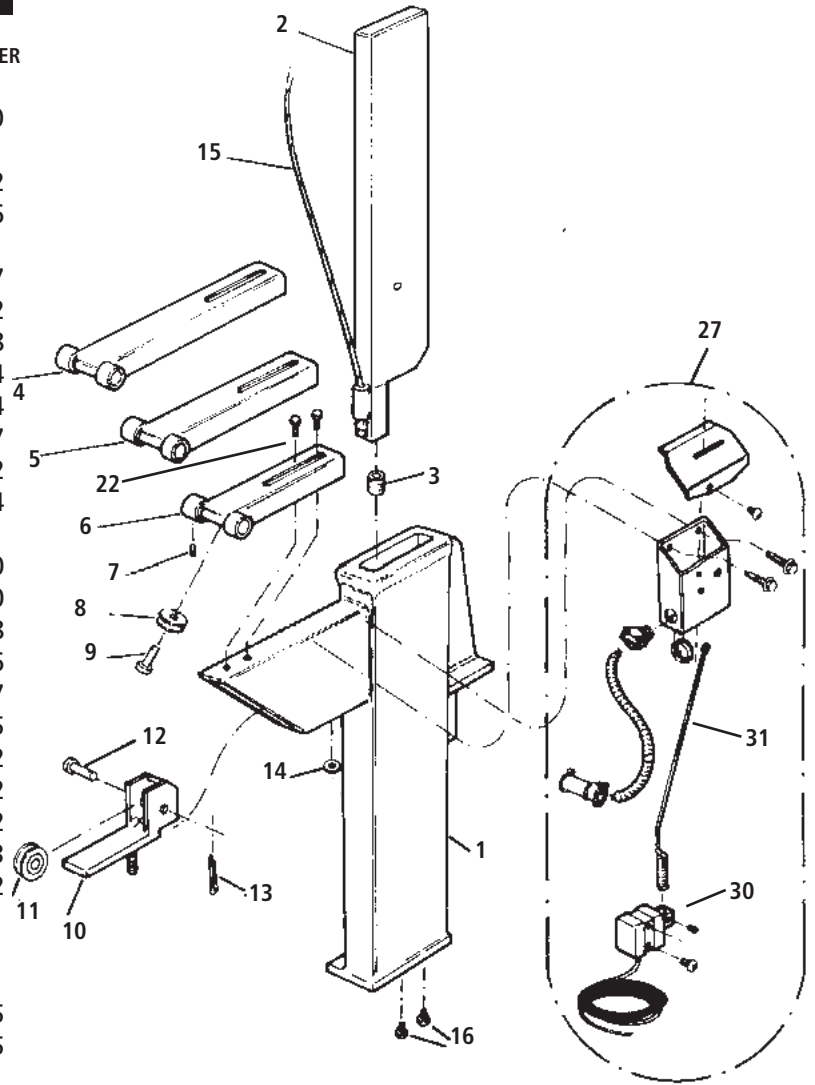

Items 1, 2, 4, 5, 6, 10, 18, 24 and 27 are sold as assemblies only

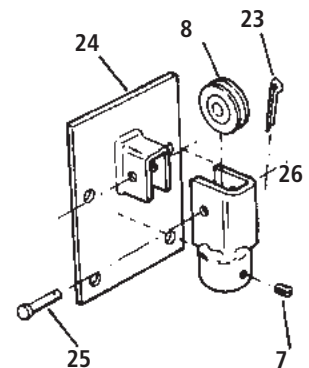
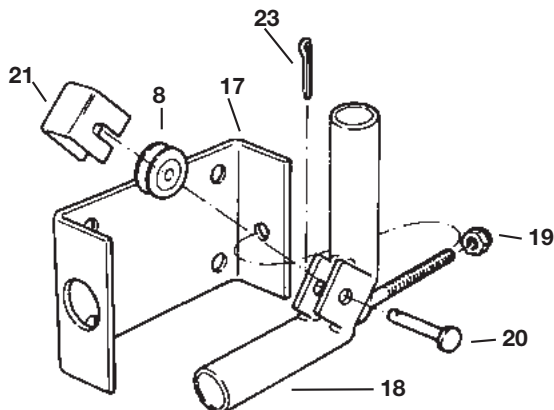

CONTROL BOX ASSEMBLY

Models 351FM and 351FP

Control Box Assembly

ITEMREQ.	DESCRIPTION	PART NO.
1	Red Lens Only	06-0-602
2	Red LEDs	06-0-632
3	Red LED Assembly	06-0-604
4	Green Lens Only	06-0-008
5	Green LEDs	06-0-633
6	Green LED Assembly	06-0-609
7	Alarm horn with contact Block	06-0-615
8	Alarm Reset PB with Contact Block	06-0-616
9	Printed Circuit Board (LED ONLY)	06-0-671
10	12V Transformer	06-0-039

ITEMREQ.	DESCRIPTION	PART NO.
11	Terminal Block 3 Pole	06-0-605
12	1,1 Fuse Block	06-0-603
13	1,1 Fuse Puller	06-0-604
14	1,1 1/2 Amp Fuse	06-0-606
15	Relay 12VDC, 2PDT with Socket	06-0-608
16	3 Position Selector Switch	06-0-631
17	LED Indicator, Blue	06-0-651
18	24V Transformer	06-0-040

Items 15, 16, 17, & 18 are available with adders to the control box
 Items 12, 13, 14, have the extra quantity listed
 with adders to the controls box

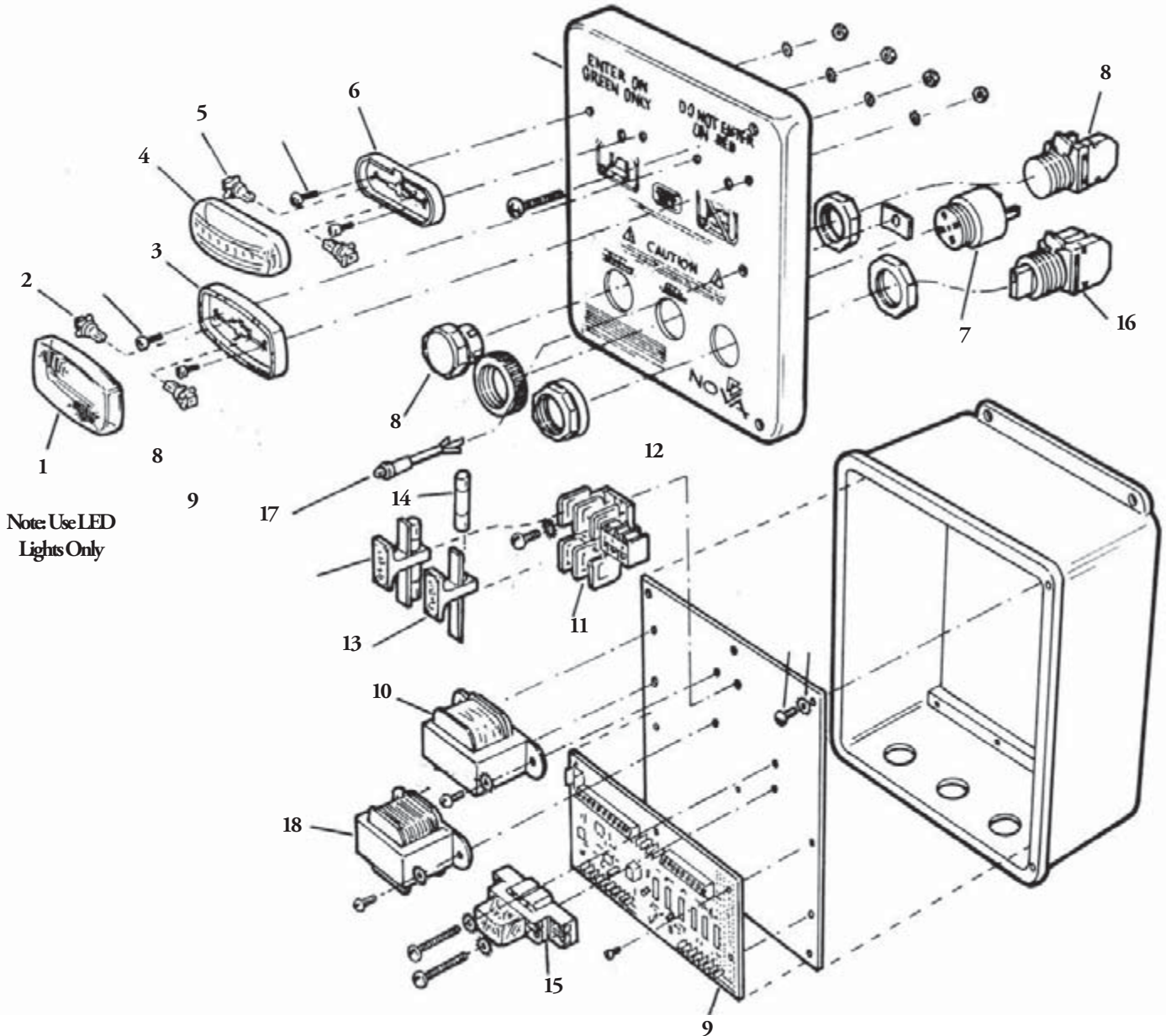

Note: Use LED
Lights Only

CONSOLE ASSEMBLY

350M and 351M Console Assembly

350M and 351M Console Assembly

ITEM	QTY	DESCRIPTION	PART NUMBER
1	1	Cable Clamp	03-0-007
2	1	Remote Box Cover Plate	41-1-018
4	1	2" Slide Pole Ass'y	31-3-917
5	1	Manual Cover Ass'y	31-3-908
6	2	Limit Switch	06-0-013*
7	4	Hex Head Bolt 3/8-16 x _	01-0-001
8	4	Star Lock Washer 3/8	01-0-002
9	1	Extension Spring	31-0-202
10	1	Pulley 2"	03-0-004
11	1	Handel Cover	31-0-062
12	2	Round Head Screw #4-40x _	01-0-006 *

13	1	Cotter Pin 1/8 x _	01-0-012
14	1	Clevis Pin 3/8 x 1-3/8	01-0-017
15	2	Round Head Screw #4-40x _	01-0-096*
16	2	Star Lock Washer #4	01-0-097*
17	2	Hex Nut #4-40	01-0-098*
18	1	Dampener	31-1-031

*Are sold with 351M only

Items 4 and 5 are sold as assemblies only

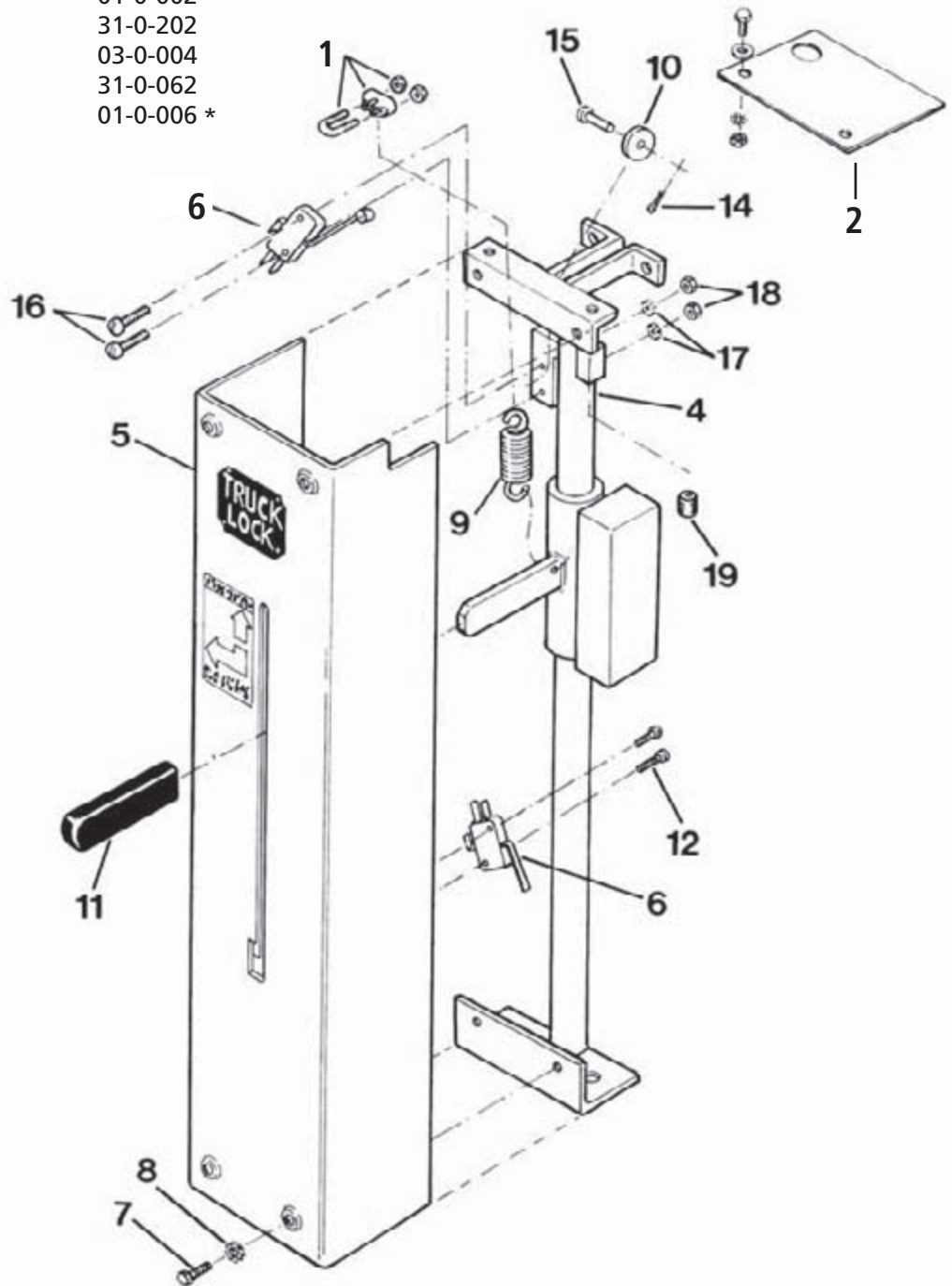

351P CONSOLE ASSEMBLY

351P and Interlock Option Console Assembly

ITEM	QTY	DESCRIPTION	PART NUMBER
1	1	P Console Cover Ass'y	31-3-310
2	1	2" Universal Cylinder Ass'y	02-3-036
3	1	10" Air Cylinder Ass'y	07-3-013
4	1	2" Rod End Ass'y	31-3-924
5	1	Remote Box Cover Plate	41-1-018
6	2	Clevis Pin 3/8 x 1-3/8	02-0-017
7	2	Cotter Pin 1/8 x _	01-0-012
8	1	Cable Clamp	03-0-007
9	1	Pulley 2"	03-0-004
10	1	Clevis Pin _ x 1-1/4	01-0-083
11	1	Cotter Pin 1/16 x _	01-0-082
12	1	90 Deg Flow Control	07-0-135
13	1	26" _" Dia Airline	07-0-007
14	2	Limit Switch	06-0-013
15	4	Round Head Screw #4-40x	01-0-006
17	4	Star Lock Washer 3/8	01-0-002

ITEM	QTY	DESCRIPTION	PART NUMBER
18	4	Hex Head Bolt 3/8-16 x _	01-0-001
19	1	Rotary Valve Ass'y	07-3-132
20	1	Union Tee	07-0-017
21	1	25 Ft _" Dia Airline	07-0-008
23	1	Solenoid Valve Ass'y	07-3-045
24	2	Screw #6-32 x 1	01-0-010
25	1	Remote Limit Switch	06-0-047
26	2	RH Screw 10-24 x 1-1/2	01-0-133
27	2	Lock Washer #10	01-0-131
28	2	Hex Nut #10-24	01-0-132
29	1	Vertical Mount Plate Door	40-1-005
30	1	Horiz. Mount Plate Leveler	40-1-004

Items 1, 2, 3, 4, 19 are sold as assemblies only
 Items 23-30 are for interconnect options only
 Keyed Rotary Valve Also Available

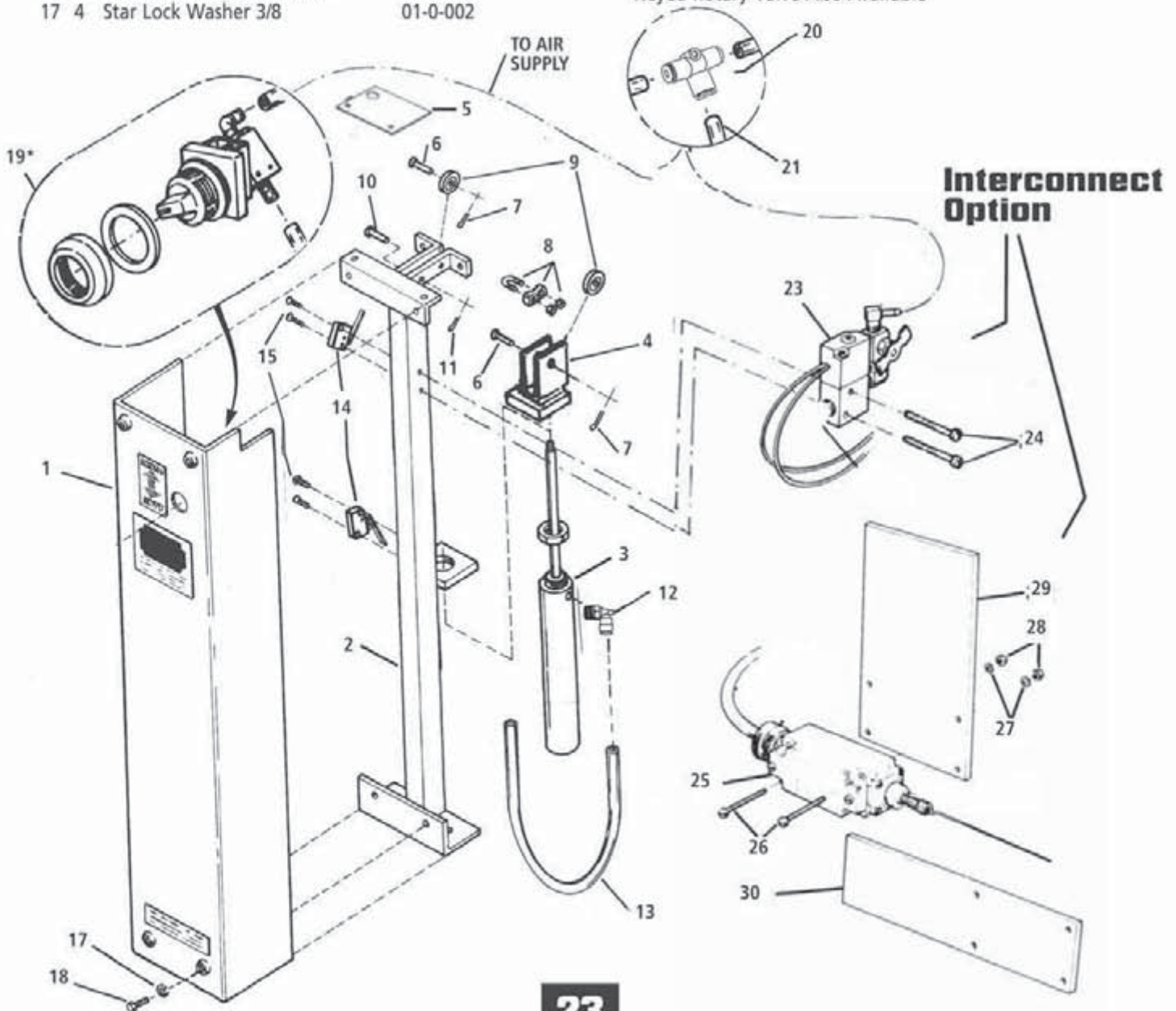

OUTSIDE LIGHT ASSEMBLY

All Models — except 350FM

ITEM	QTY	DESCRIPTION	PART NUMBER
1	1	Stop & Go Signal Light LED	06-0-700-LED
2	1	Red LED Assembly	06-0-723
3	1	Green LED Assembly	06-0-724
4	4	Screw and Clips	06-0-725

Outside Sign, Stop/Red NT-0-106

Note: Use LED Lights Only

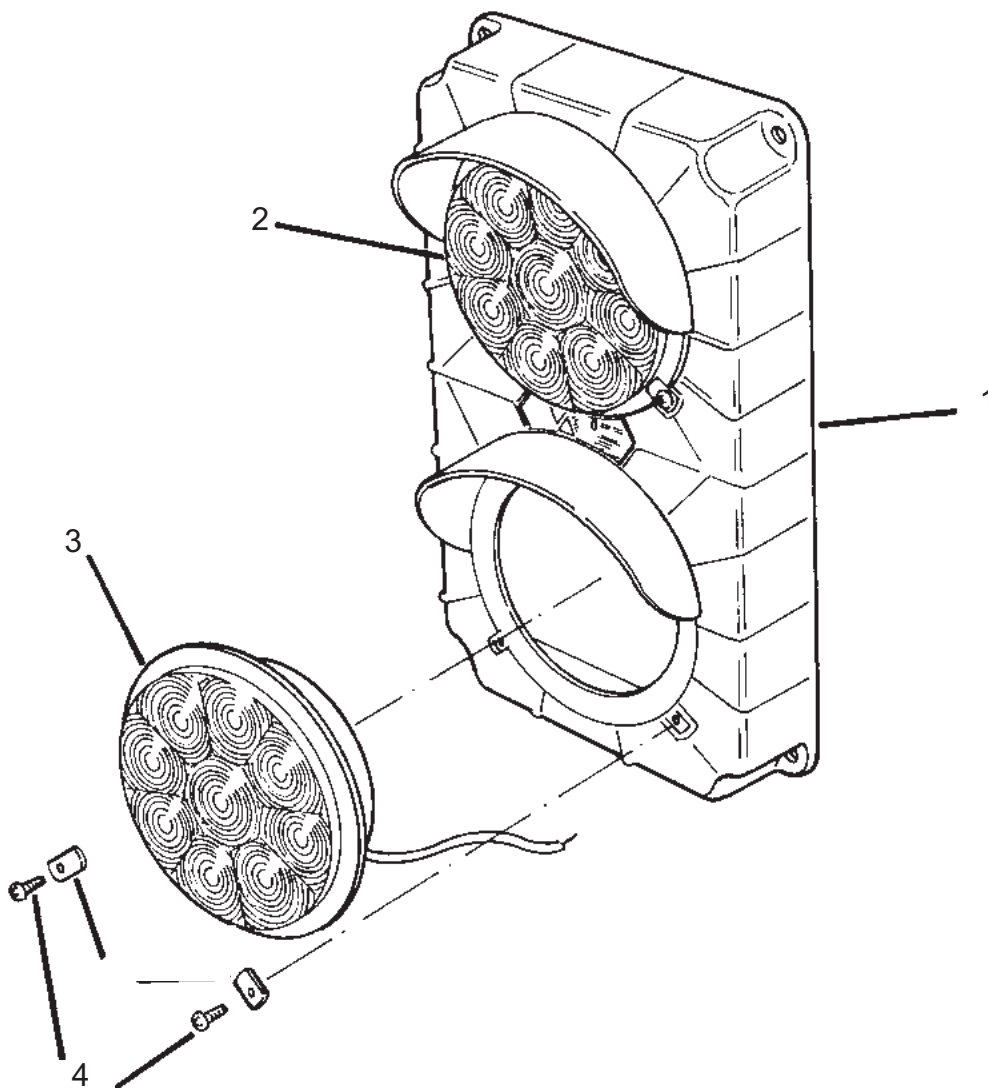



NOVA 350 SERIES TRUCK LOCK™ MANUAL

©2010 NOVA TECHNOLOGY INT'L, LLC.

NOVA Technology Int'l, LLC • N90 W14507 Commerce Drive, Menomonee Falls WI 53051

Phone: 262-502-1591. Toll Free: 800-236-7325. Fax: 262-502-1511. www.novalocks.com

NOVA TRUCK LOCK & LOGOS ARE TRADEMARKS OF
NOVA TECHNOLOGY INT'L, LLC. All Rights Reserved.

Printed on Recycled Paper, Illustrations by R.F.. Schwengel