



NMS Mechanical Dock Leveler

Owner's/User's Manual



NOVA Technology International, Inc. | N90W14507 Commerce Drive Menomonee Falls, WI 53051
Phone 262-502-1591 | 800-236-7325 | fax 262-502-1511 | www.novalocks.com

Printed in USA
© 2010

Manual No. 4111-0019N
June 2010
November 2010

Table of Contents

	Page
Safety	
Recognize Safety Information	1
General Operational Safety Precautions	1
Operational Safety Precautions	2
Maintenance Safety Precautions	4
Safety Decals	5
Owner's/User's Responsibilities	6
Introduction	
General Information	7
Dock Leveler Stock Specifications	7
Component Identification	8
Installation	
Prepare Pit	9
Prepare Dock Leveler	10
Install Dock Leveler	12
Operation	
Theory	17
Operating Instructions	18
Ramp Loading/Unloading Instructions	19
End Loading/Unloading Instructions	20
Maintenance	
Service Dock Leveler Safely	21
Periodic Maintenance	22
Adjustments	
Adjust Lift Arm Spring and Lip Assist Spring Tension	24
Adjust Lip Stop Bolt	26
Troubleshooting	
Troubleshooting	27
Parts	
Hold-Down Mechanism	29
Frame Components	30
Platform Components	32
Toe Guard/Weather Seal—Optional	36
Miscellaneous	
Customer Information	37
Warranty	Back Cover

Recognize Safety Information

Safety-Alert Symbol



The Safety-Alert Symbol identifies important safety messages on equipment, safety signs, in manuals, or elsewhere. When you see this symbol, be alert to the possibility of personal injury or death. Follow the instructions in the safety message.

DANGER

The use of the word DANGER signifies the presence of an extreme hazard or unsafe practice which will most likely result in severe injury or death.

WARNING

The use of the word WARNING signifies the presence of a serious hazard or unsafe practice which may result in serious injury or death.

CAUTION

The use of the word CAUTION signifies possible hazard or unsafe practice which could result in personal injury.

IMPORTANT

The use of the word IMPORTANT is to draw attention to a procedure that needs to be followed to prevent machine damage.

General Operational Safety Precautions



Read and understand the operating instructions and become thoroughly familiar with the equipment and its controls before operating the dock leveler.

Never operate a dock leveler while a safety device or guard is removed or disconnected.

Never remove DANGER, WARNING, or CAUTION signs or decals on the equipment unless replacing them.



DO NOT activate the equipment until all unauthorized personnel in the area have been warned and have moved outside the operating zone.

Remove any tools or foreign objects from the operating zone before starting.

Keep the operating zone free of obstacles that could cause a person to trip or fall.

SAFETY

Operational Safety Precautions



Learn the safe way to operate this equipment. Read and understand the manufacturer's instructions. If you have any questions, ask your supervisor.

DANGER



Stay clear of dock leveling device when freight carrier is entering or leaving area.



Do not move or use the dock leveling device if anyone is under or in front of it.



Keep hands and feet clear of pinch points. Avoid putting any part of your body near moving parts.

WARNING



Chock/restrain all freight carriers. Never remove the wheel chocks until loading or unloading is finished and truck driver has been given permission to drive away.



Do not use a broken or damaged dock leveling device. Make sure proper service and maintenance procedures have been performed before using.



Make sure lip overlaps onto trailer at least 4 in. (102 mm).



Keep a safe distance from both side edges.

⚠ WARNING

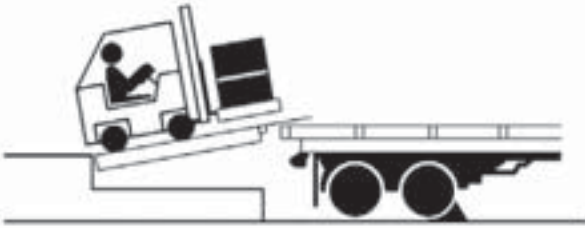

Do not use dock leveling device if freight carrier is too high or too low.



Do not overload the dock leveling device.



Do not operate any equipment while under the influence of alcohol or drugs.



Do not leave equipment or material unattended on dock leveling device.

SAFETY

Maintenance Safety Precautions

WARNING



Always post safety warnings and barricade the work area at dock level and ground level to prevent unauthorized use of the unit before maintenance is complete.

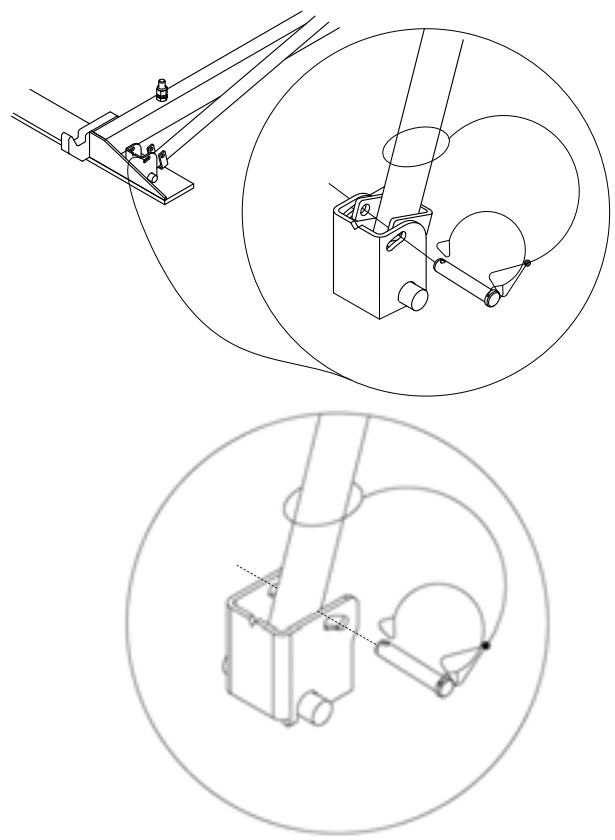

When engaging the maintenance prop ensure the bridge pin is set in place and closed before servicing or maintaining the unit.

WARNING

DO NOT grind or weld if hydraulic fluid or other flammable liquid is present on the surface to be ground or welded

DO NOT grind or weld if uncontained hydraulic fluid or other flammable liquid is present. Stray sparks can ignite spills or leaks near the work area. Always clean up the oil leaks and spills before proceeding with grinding or welding.

Always keep a fire extinguisher of the proper type nearby when grinding or welding.

Failure to follow these instructions may result in serious personal injury or death.







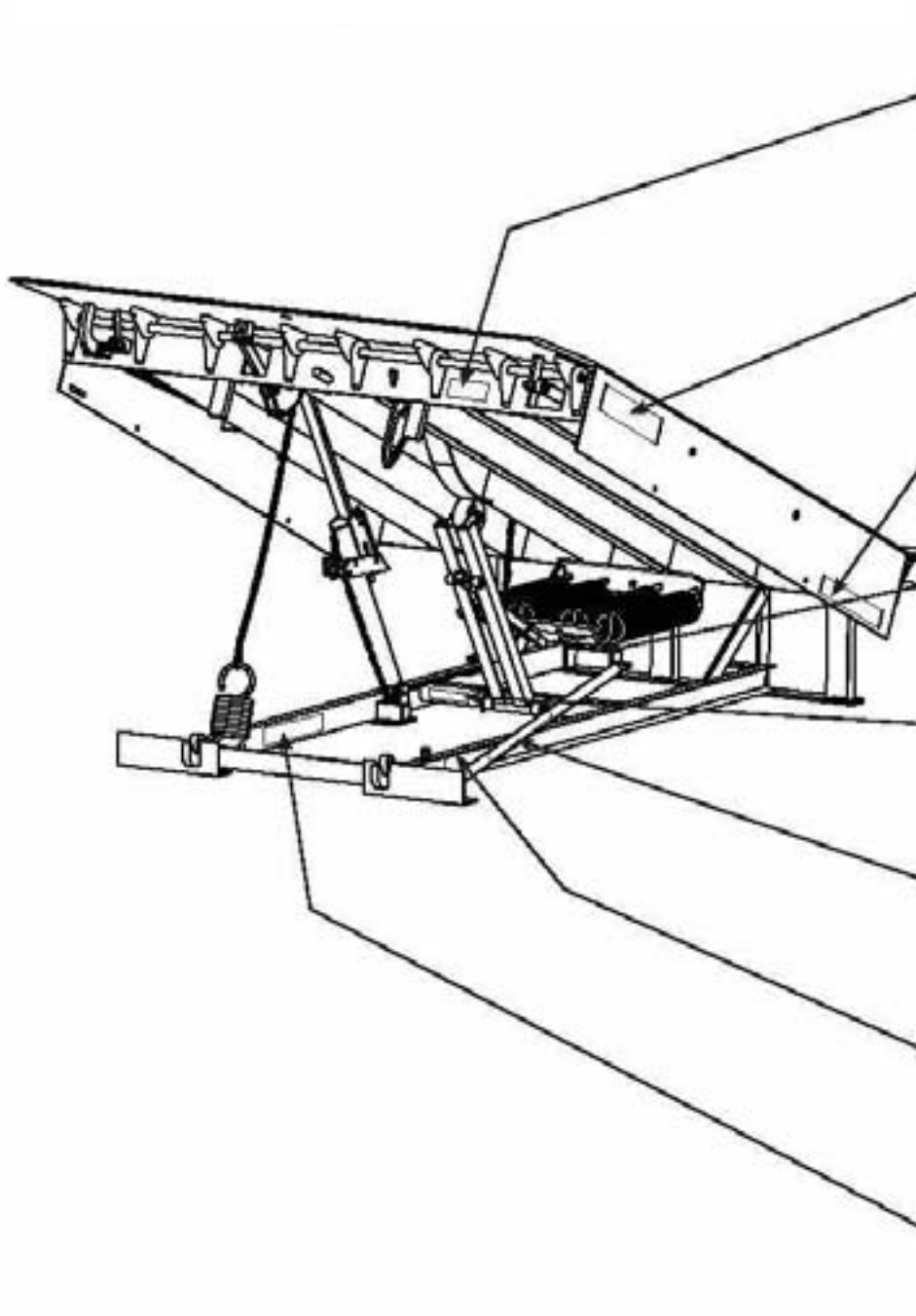

WARNING

ALWAYS stand clear of dock leveler lip when working in front of the dock leveler. Failure to do this may result in serious personal injury or death.

Safety Decals

Every 90 days (quarterly) inspect all safety labels and tags to ensure they are on the dock leveler and are easily legible. If any are missing or require replacement, please call 1-800-236-7325 for replacements.

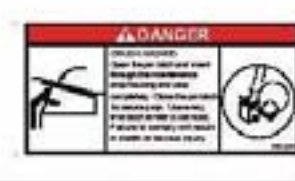

<p>1751-0727</p>	
<p>1751-0730 (x2)</p>	 <p><i>(decal placed in same position on both sides)</i></p>
<p>1751-0329 (x2)</p>	 <p><i>(decal placed in same position on both sides)</i></p>
<p>1751-0330 (x2)</p>	 <p><i>(decal placed in same position on both sides)</i></p>
<p>1751-0728</p>	
<p>1751-0729</p>	
<p>1751-0731</p>	
<p>1751-0726</p>	

OWNER'S/USER'S RESPONSIBILITIES

1. The owner/ user should recognize the inherent dangers of the interface between the loading dock and the transportation vehicle. The owner/ user should, therefore, train and instruct all operators in the safe operation and use of the loading dock equipment in accordance with manufacturer's recommendations and industry standards. Before operation of the equipment, all operators shall read, understand and be familiar with all functions of equipment as described in the owner's/user's manual.
2. The manufacturer shall provide to the initial purchaser all necessary information with regards to: Safety Information, Operation, Installation and Safety Precautions, Recommended Initial and Periodic Inspections Procedures, Planned Maintenance Schedule, Product Specifications, Troubleshooting Guide, Parts Break Down, Warranty Information and Manufacturers Contact Information. The owner/ user shall be responsible to verify that this information is available and received as well as proper instructions, training and familiarity of the equipment for all operators has been completed. Owner's/ User's shall actively maintain, update and re train all operators on safe working habits and operations of the equipment.
3. It is recommended when the transportation vehicle is positioned correctly in the dock opening and in contact with both bumpers, there shall be a minimum of 4.00 inches (100mm) overlap of the leveling device and the transportation vehicle at all times during the loading and unloading process.
4. Name plates, placards, decals, instructions and posted warnings shall not be obscured from the view of the operator or maintenance personnel for whom such warnings are intended for. Contact manufacturer for any replacements.
5. Manufacturer's recommended periodic maintenance and inspection procedures in effect at the date of shipment shall be followed at all times. Written documentation of maintenance, replacement parts or damage should be retained. In the event of damage notification to the manufacturer is requested.
6. Any modifications or alterations of loading dock equipment shall only be done with prior written approval from the original equipment manufacturer.
7. When industrial moving devices are being used in the loading or unloading of product from the transportation vehicle, this vehicle shall have the brakes and wheel chocks applied appropriately or all other positive restraining device shall be fully utilized.
8. Loading dock safety equipment should never be used outside of its intended use, range, or capacity. Please consult the manufacturer if you have any questions as to the use, range or capacity of the equipment.
9. When selecting loading dock safety equipment, it is important to consider not only present requirements but also future plans and any possible adverse conditions, environments or use.

General Information

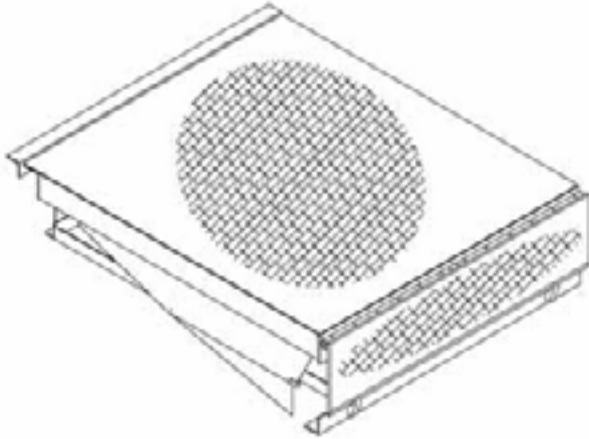

Congratulations on your choice of a NOVA dock leveler. This manual covers the NMS-series mechanical dock leveler.

Designed by NOVA to be a marvel of simplicity and efficiency, your dock leveler, when properly installed, will provide many years of trouble-free performance with an absolute minimum of maintenance. To obtain maximum performance and longest possible use, a simple program of preventive maintenance is recommended.

Once again, thank you and congratulations on your purchase of a NOVA mechanical dock leveler.

Dock Leveler Stock Specifications

NMS Series Mechanical Dock Levelers dock levelers are available in the following sizes, weight capacities, and options:

Width

6 ft (1828.8 mm)
6-1/2 ft (1981.2 mm)
7 ft (2133.6 mm)

Length

6 ft (1828.8 mm)
8 ft (2438 mm)
10 ft (3048 mm)

Capacity (CIR*)

25,000 lb (11 340 kg)
30,000 lb (13 608 kg)
35,000 lb (15 876 kg)
40 000 lb (18 144 kg)
45 000 lb (20 412 kg)
55 000 lb (22 680 kg)

* CIR (Comparative Industry Rating)

Call NOVA for your specific needs.

INTRODUCTION

Component Identification

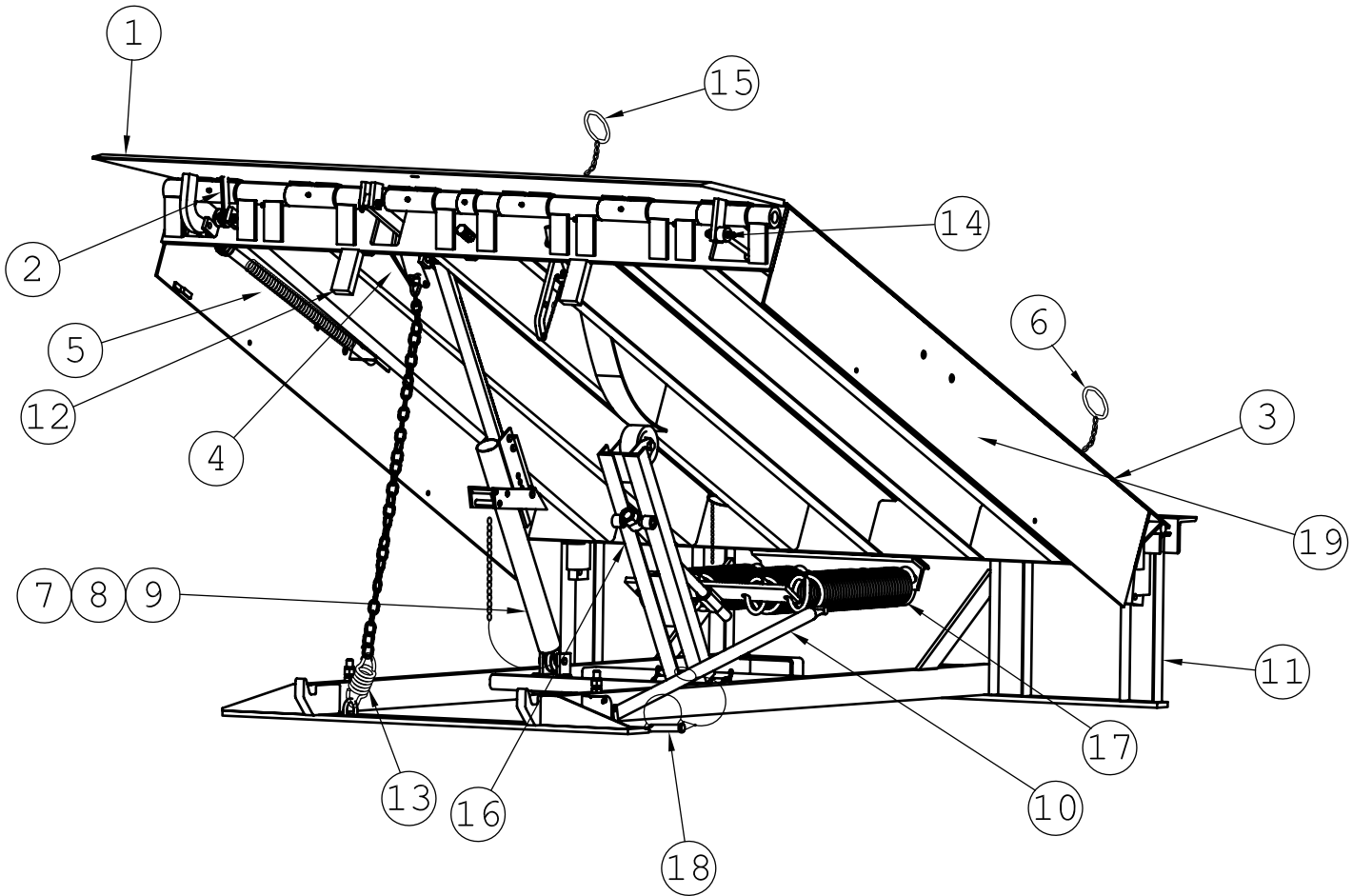

- | | | | |
|--------------------------|-------------------------------|--------------------------|------------------------------|
| 1 — Lip | 6 — Hold Down Release Ring | 11— Main Base Frame | 15— Safety Leg Pull Chain |
| 2 — Lip Maintenance Prop | 7 — Ratchet Pawl | 12— Safety Leg Assy. | 16— Lift Arm Assembly |
| 3 — Platform | 8 — Ratchet Bar | 13— Lip (Snubber) Spring | 17— Lift (Main) Spring |
| 4 — Lip Link | 9 — Hold Down | 14— Lip Shock Absorber | 18— Prop. Pin and Clip |
| 5 — Lip Assist Spring | 10— Platform Maintenance Prop | | 19— Working Range Toe Guards |

Prepare Pit

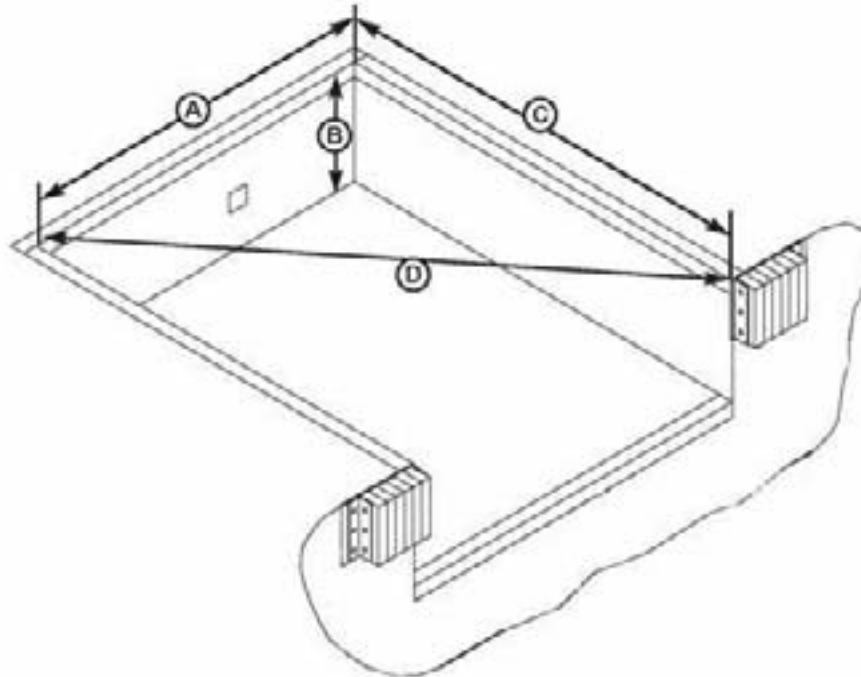

A—Distance (Pit Width)
(Front and Rear)

B—Distance (Dock Floor-to-Pit
Floor) (All Four Corners)

C—Distance (Pit Length)
(Both Sides of Pit)

D—Distance (Pit Corner-to-Corner)
(Top, Bottom, and Both Sides)



WARNING

Post safety warnings and barricade the work area at dock level and ground level to prevent unauthorized use of the dock leveler before installation has been completed.

Failure to follow the installation instructions can result in damage to dock leveler, the facilities, and/or serious personal injury or death.



CAUTION

Only trained installation professionals with the proper equipment should install this product.

IMPORTANT

DO NOT remove the shipping bands around the dock leveler lip until instructed to do so.

Before lowering the dock leveler into the pit, the following must be performed:

1. Remove all debris from the pit and sweep the pit clean.
2. Check the entire dock leveler pit for proper construction according to approved/certified pit drawings. Make sure pit is square by making the following measurements:

- Measure pit width distance (A) at both front and rear of pit.
- Measure dock floor-to-pit floor distance (B) at all four corners.
- Measure pit length distance (C) at both sides.
- Measure corner-to-corner (criss-cross) distance (D) at both sides. Take measurements at dock floor level and at pit floor level.

If any measurement is off by more than 1/8 in. (3.18 mm), contact NOVA Technical Services before proceeding.

INSTALLATION

Prepare Dock Leveler

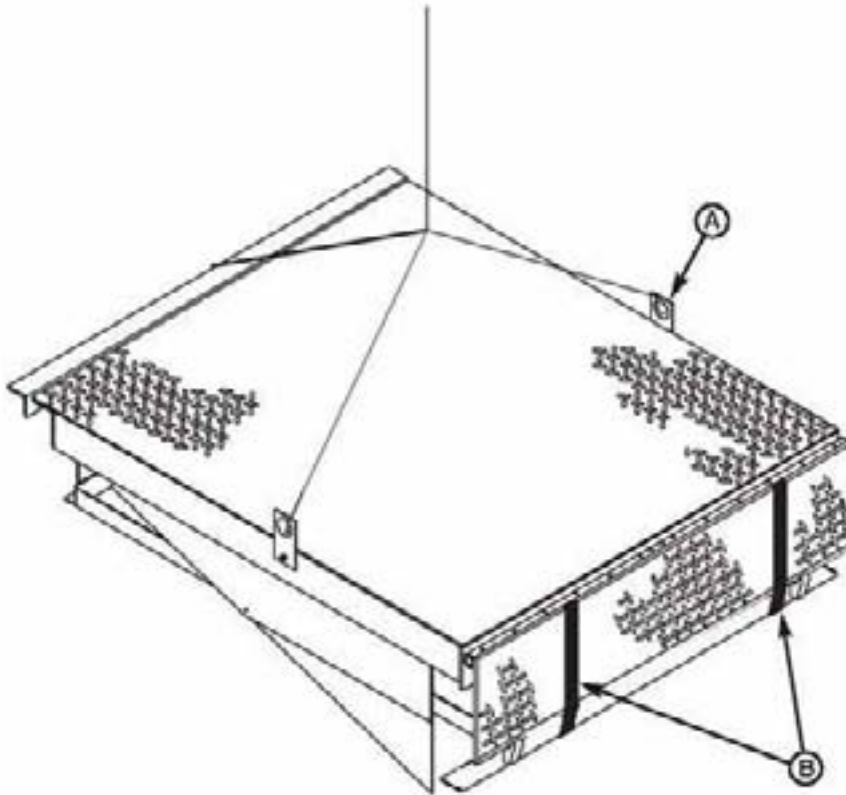

A—Lifting Bracket (2 used)

B—Shipping Bands



WARNING

The dock leveler is heavy. Use a lifting device and chains with the appropriate lifting capacity and reach.

Always use the lifting brackets provided with the unit whenever lowering or lifting a dock leveler into or out of a pit.

Failure to follow these instructions may result in damage to the dock leveler and/or serious personal injury or death.

NOTE: A third sling may be used to install the unit as needed.

NOVA dock levelers are designed with installation in mind. Each unit is shipped with lifting brackets (A) fastened to the platform side joists.

IMPORTANT

DO NOT remove the shipping bands (B) around the platform lip and leveler frame at this time. The shipping bands are needed to hold the leveler together during the installation process.

1. Remove any bumpers that may be banded, or bolted to the frame of the dock leveler.

DO NOT remove the shipping bands (B) around the platform lip and leveler frame at this time.

IMPORTANT

DO NOT over-tighten the lifting bracket hardware. Over-tightening can damage the weather seal, if equipped.

NOTE: Overall width of platform and lifting brackets (A) must be kept to a minimum to prevent interference between the lifting brackets and the pit walls as the dock leveler is lowered into the pit.

2. Make sure the mounting hardware of lifting brackets (A) is snug. The brackets should pivot relatively freely on the mounting cap screw. DO NOT over-tighten.
3. Attach lifting chains to lifting brackets (A) and to a lifting device (i.e., hoist or fork truck) having the appropriate lifting capacity and reach.

4. Remove wood blocks that are attached to the leveler frame before putting the dock leveler into the pit.

5. To pick up the unit from the rear, slide forks into the fork slots and under the cross member. Shown below.

6. To pick up the unit from the front, move forks closer together and slide over the frame and under the cross member. It may be necessary to unband the unit to gain access to the front, by lifting the lip up then sliding the forks under the cross member.

REAR PICK UP

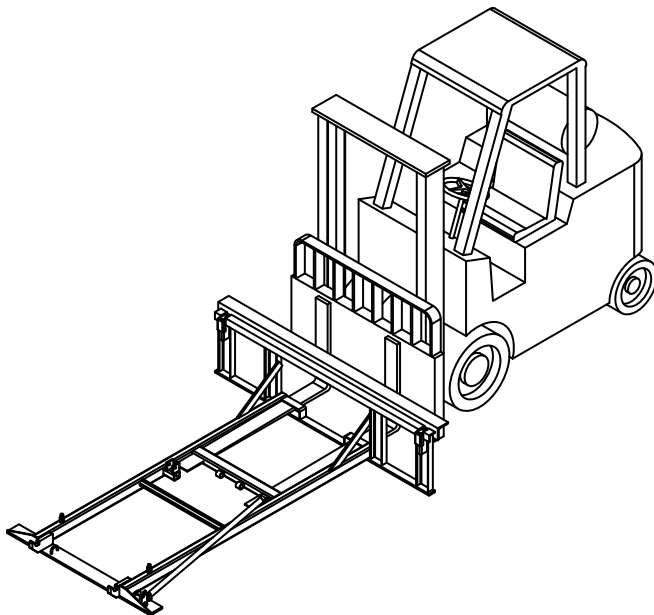

FRONT PICK UP

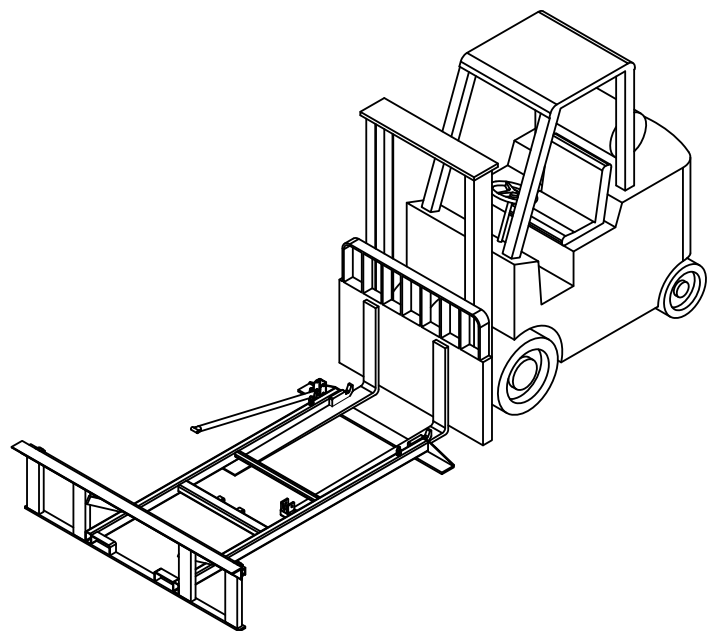

INSTALLATION

Install Dock Leveler

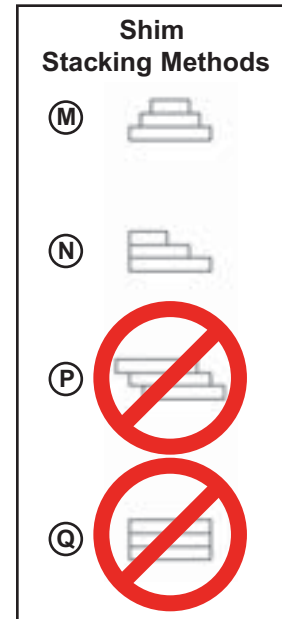
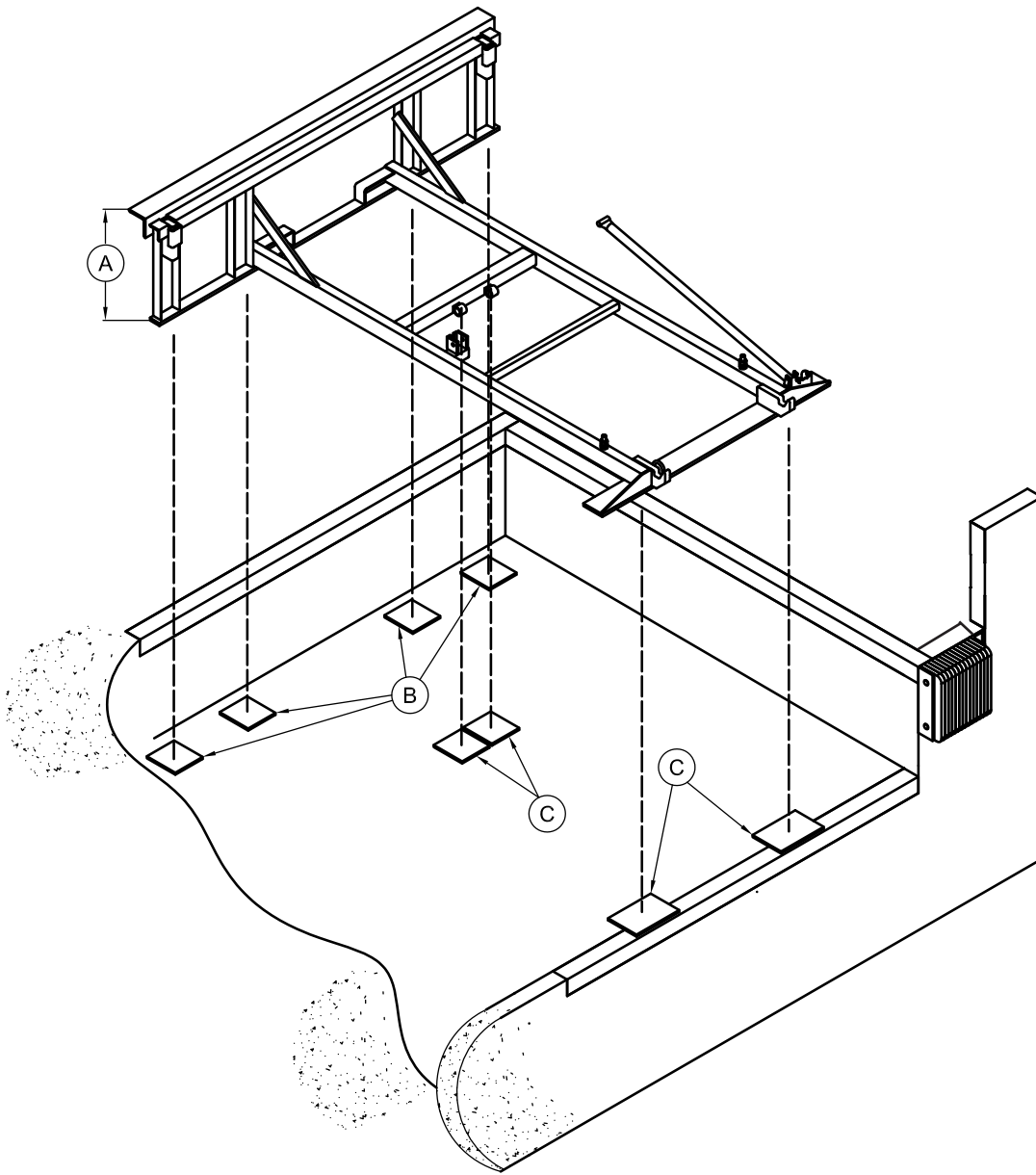

- A—Distance (Leveler Frame Height)
- B—Shim Locations (Under Rear Vertical Supports, 4-5 Places TYP)
- C—Shim Locations (Under Lip Keepers, Lifter Arm and Prop)
- D—Dock Floor
- E—Rear Pit Curb Angle
- F—String
- G—Rear Hinge Frame Angle
- H—Distance (Dock Floor-to-Pit Floor)
- J—Distance (Top of Shim Stack-to-Dock Floor)
- K—Shim Stack
- L—Dock Leveler Frame
- M—Pyramid (Preferred)
- N—Stepped (Acceptable)
- P—Offset (Not Acceptable)
- Q—Straight (Not Acceptable)

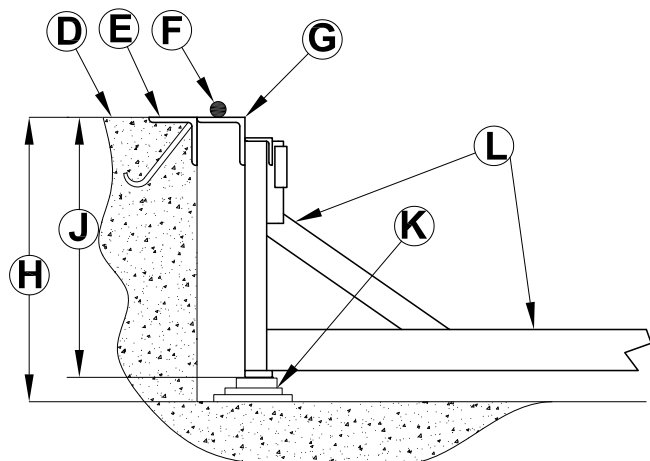

NOTE: NOVA dock levelers are designed with a nominal 1/2 in. (12.7 mm) shimming distance to allow for pit inconsistencies.

1. Determine height of shim stack (K) for each shim location (B) by performing the following:
 - a. Measure leveler frame height distance (A).
 - b. Measure dock floor-to-pit floor distance (H) at each shim location (B). Write down the dimensions obtained at each location.
 - c. Subtract distance (A) from distance (H) to obtain the shim height. Repeat for each shim location.

IMPORTANT

The minimum size of the shim that contacts the leveler frame (i.e., the top shim of each shim stack) must be at least 4-1/2 x 4-1/2 in. (114.3 x 114.3 mm) to support the full width of the frame rail and to provide a shelf for a fillet weld.

Use the thickest shim stock possible for stability and weld penetration purposes. DO NOT use multiple layers of 1/8 in. (3.18 mm) or thinner shim stock.

2. Using the results obtained in step 1, create the individual shim stacks on the pit floor at locations (B). Build each shim stack (K) using the pyramid method (M) (preferred) or stepped method (N) with the top shim having a minimum size of 4-1/2 x 4-1/2 in. (114.3 x 114.3 mm) and each successive lower shim being larger so the shims can be welded together using a fillet weld. DO NOT use offset method (P) or straight method (Q).

NOTE: To assist in obtaining an accurate measurement of distance (J), use a string (F) pulled tight across the pit opening, directly over the shim locations.

3. Verify that each shim stack is at the correct height by measuring distance (J) [top of shim stack (K) to dock floor]. Distance (J) must equal the dock leveler height (A).

4. Put a 1/4 in. (6.6 mm) thick shim at locations (C) (under lip keepers/maintenance prop and safety legs). Make sure shims are larger than frame front flat so pyramid or stepped stacking method can be used.

NOTE: A 1/4 in. (6.6 mm) thick shim at locations (C) is used only as a starting point. The final shim stack height will be determined after the dock leveler is lowered into the pit.

WARNING

The dock leveler is heavy. Use chains and a lifting device with the appropriate lifting capacity and reach. Failure to do so may result in damage to dock leveler and/or serious personal injury or death.

5. Using an appropriate lifting device connected to the lifting brackets, lower dock leveler into the pit so rear hinge frame angle (G) is tight against rear pit curb angle (E) across full width of the leveler frame.
6. Allow rear of dock leveler to rest on the rear shims while keeping the front of the dock leveler level with the dock floor.
7. Add shims at front shim locations (C) so front of dock leveler will stay level with dock floor when leveler is resting fully on shims.

INSTALLATION

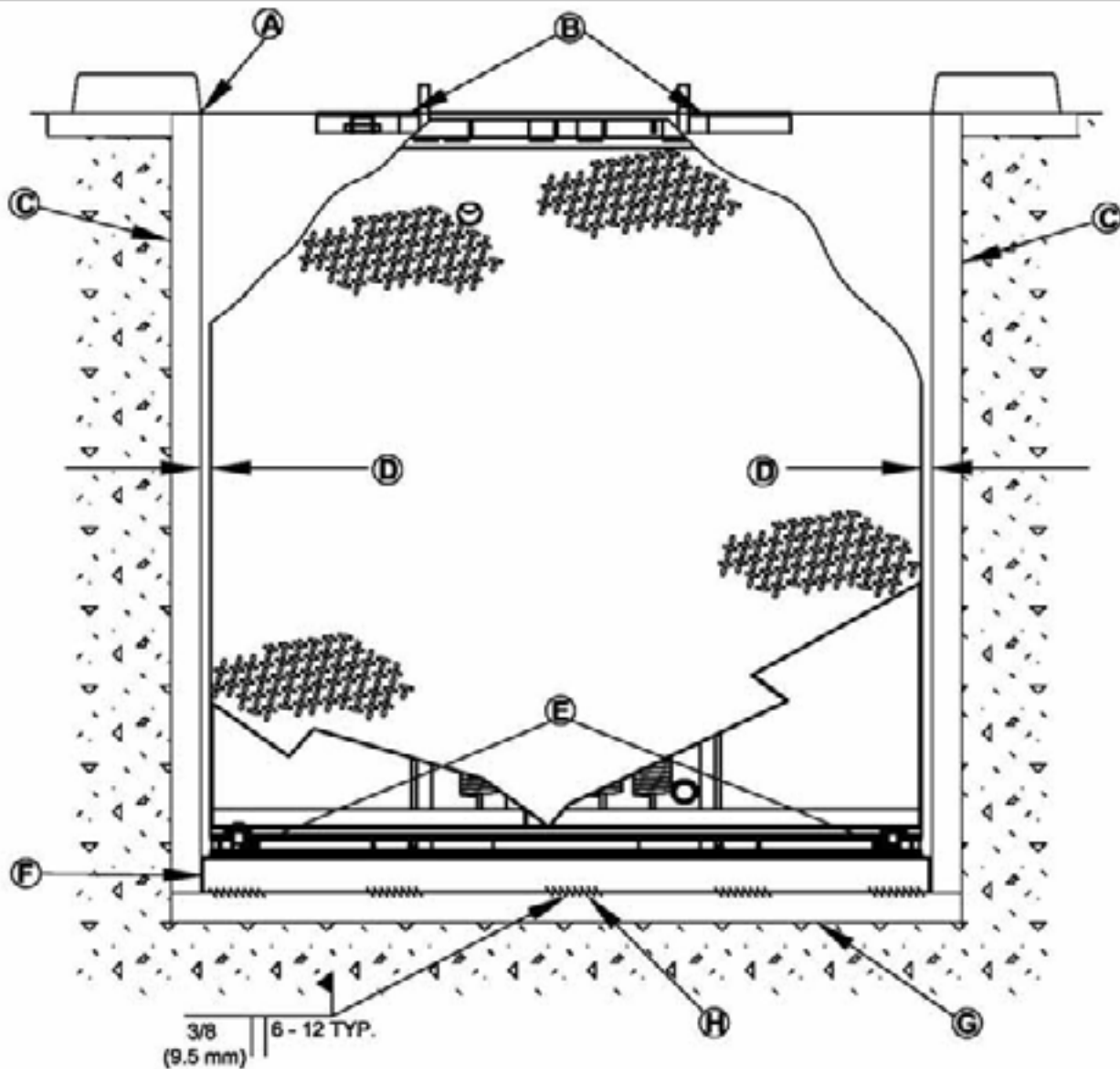

- | | | | |
|----------------------|---------------------------------|--------------------------|--|
| A—Front of Dock Pit | C—Side Pit Curb Angle | E—Pry Locations | G—Rear Pit Curb Angle |
| B—Dock Leveler Frame | D—Gap [3/4 in. (19 mm) Minimum] | F—Rear Hinge Frame Angle | H—Flare Bevel Weld, Typical (To Fit Spacing) |

8. With rear hinge frame angle (F) tight against rear pit curb angle (G), perform/check the following:
 - Pry between the platform and rear hinge frame angle at locations (E) to make sure rear edge of platform is parallel to the rear hinge frame angle (F).
 - Gap (D) must exist equally along both sides of leveler so weather seal (if equipped) will not bind during dock leveler operation.
9. If gap (D) cannot be obtained equally at both sides of leveler, grind or add material at the rear edge of rear hinge frame angle (F) as needed.
10. Allow the dock leveler to rest fully on the shim stacks. Make sure the leveler is in the cross-traffic (stored) position with lip resting on lip keepers.
11. Check that a smooth and level transition exists between the dock floor and the dock leveler platform. Add or remove shims as necessary until a smooth transition is obtained.
12. If leveler cannot be squared and made level as instructed in steps 8 – 10, contact NOVA Technical Services.



WARNING

DO NOT grind or weld if hydraulic fluid or other flammable liquid is present on the surface to be ground or welded.

DO NOT grind or weld if uncontained hydraulic fluid or other flammable liquid is present. Stray sparks can ignite spills or leaks near the work area. Always clean up the oil leaks and spills before proceeding with grinding or welding.

Always keep a fire extinguisher of the proper type nearby when grinding or welding.

Failure to follow these instructions may result in serious personal injury or death.

IMPORTANT

Always ground welding equipment to the dock leveler frame, NEVER to the platform.

DO NOT weld continuously along the full length of the rear hinge frame angle. This can put unnecessary stress on the leveler components, causing the leveler not to function correctly and shorten the lifespan of the affected components.

NOTE: The illustration on the previous page shows a typical weld pattern. The weld pattern will vary slightly depending on size of dock leveler.

13. With the rear hinge frame angle (F) tight against the rear pit curb angle (G), weld the rear hinge frame angle (F) to the rear pit curb angle (G) using a 3/8 in. (9.5 mm) flare bevel skip weld —each weld being 6 in. (152 mm) long.

Start at each end with a 6 in. (152 mm) long weld. Space all the other welds out evenly leaving approximately 6 in. (152 mm) space between each weld.

Alternate welding locations to distribute heat. Welding sequentially from one end to the other may cause warping or distortion.

14. Remove shipping bands at this time. Allow platform to float. Add/Remove shims as necessary to bring platform level/flush with floor.



WARNING

Make sure all personnel are outside of the leveler operating zone and stand clear of the platform lip before removing the shipping bands. Failure to do this may result in serious personal injury or death.

15. Weld front of dock leveler frame (B) to shims located under the keepers, then weld the shims to the front pit curb steel.
16. Disconnect lifting device and chains from the lifting brackets.



WARNING

Make sure all personnel are outside of the leveler operating zone and clear of the platform lip before activating the leveler. Failure to do this may result in serious personal injury or death.

IMPORTANT

When activating the leveler, always pull AND hold the platform release ring until the platform is at the full-raised position. Releasing the ring while the platform is still rising may result in damage to the equipment.

17. Pull and hold the release ring (located in recess at rear of platform) until the platform is fully raised. Check for binding as platform rises.
18. Slowly walk out onto the platform to lower the platform. Allow the platform to lower to the cross-traffic position. Check for binding as platform lowers.
19. If binding occurs, reposition leveler and/or add or remove shims as necessary. Raise and lower platform again. If platform still binds, contact NOVA Technical Services for further instructions.
20. Check that the leveler is flush with the dock floor and that the platform lip contacts both lip keepers evenly.

INSTALLATION

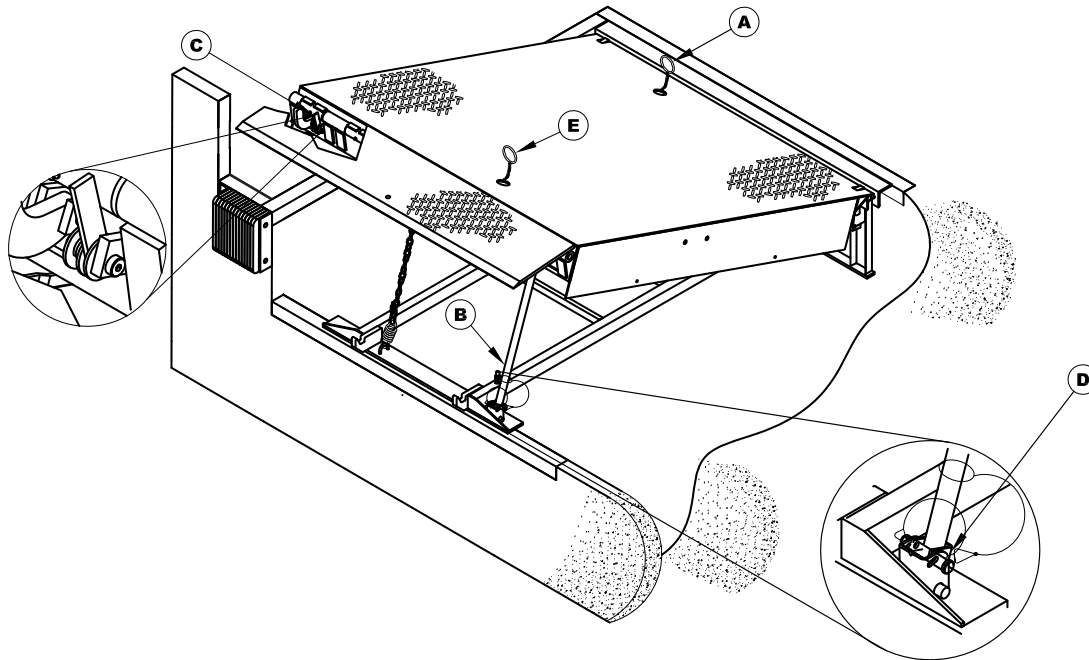

A—Platform Release Ring B—Platform Maintenance Prop C—Lip prop support D— Prop Pin and Clip E—Safety Leg Pull Chain

21. Pull the release ring (A) to raise platform. Engage the platform maintenance prop (B) in the service (upright) position and lock the maintenance prop at this position using an OSHA approved locking device, supplied by others. Engage lip maintenance prop(C).

⚠ WARNING

Make sure the platform is properly supported in the raised position before entering the pit to finish weld the shims. Failure to do this may result in serious personal injury or death.

22. Install shims under lift arm at locations using the pyramid shimming method. (Page 12)The lift arm pivot must be solidly shimmed the entire length of the lift arm pivot. Make sure the lift arm pivot is level from side-to-side.

23. Finish weld all shims using a fillet weld.

- Weld all shims within each shim stack to each other, then weld the shim stack to the leveler frame.
- Weld the front leveler frame shim stacks to the front pit curb steel if not done previously.

24. When all welding has been completed, remove all slag then paint all the welds and shims.

25. Remove the lifting brackets from the platform side joists.

26. Disengage the platform maintenance prop.

27. Slowly walk out onto the platform to lower the platform until it is at the cross-traffic (stored) position.

28. Check operation of dock leveler by cycling the leveler at least four times.

- When the platform is at full height, lip will be fully extended.
- Lip will begin to drop after the unit begins to lower to truck bed.

29. Check below-dock position by walking platform down before lip folds completely.

- Lip will be over lip keepers.
- Platform safety legs will be resting on frame.

30. Check full below-dock position by walking the platform down. Pull and hold safety leg chain (E) before lip folds completely.

31. If the lip does not extend fully or lip folds too quickly, see appropriate symptom in the Troubleshooting section.

32. Install the dock bumpers as required, clean weld splatter and touch up with spray paint.

Theory

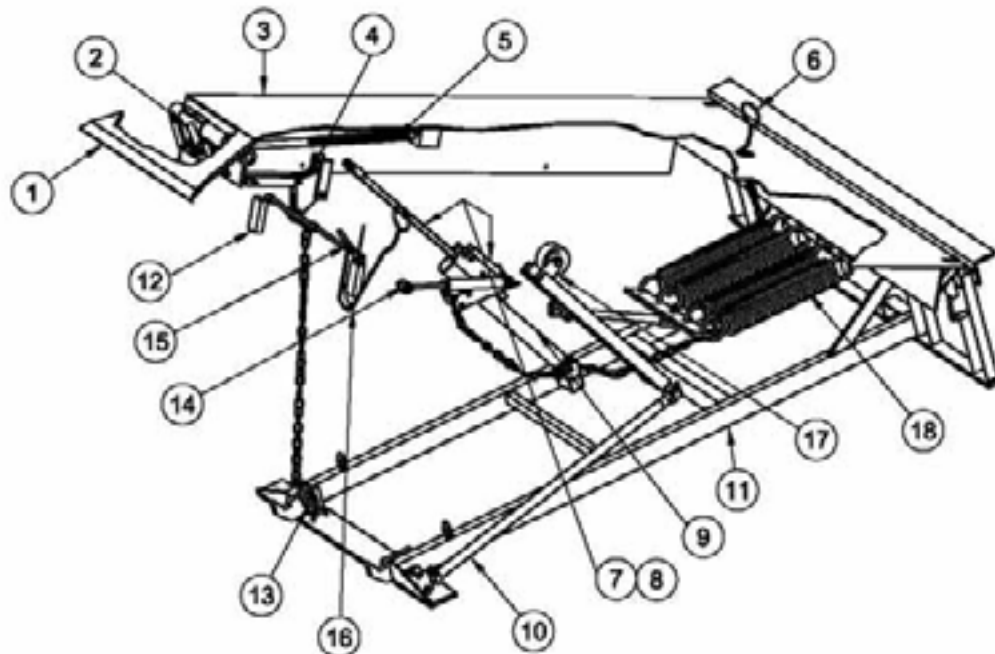

- | | | | |
|------------------------|--------------------------|------------------------------|----------------------------------|
| 1—Lip | 6—Hold Down Release Ring | 10—Platform Maintenance Prop | 15—Safety Leg Below Dock Control |
| 2—Lip Maintenance Prop | 7—Ratchet Pawl | 11—Main Base Frame | 16—Safety Leg Retract Pull Ring |
| 3—Platform | 8—Ratchet Bar | 12—Safety Leg Assy. | 17—Lift Arm |
| 4—Lip Link | 9—Hold down | 13—Snubber Spring | 18—Lift Springs |
| 5—Lip Assist Spring | | 14—Gas Shock | |

The NMS-series mechanical dock leveler uses large lift springs (18) to apply force to lift arm (17). The lift arm pushes against the underside of the platform (3), rolling on the cam (not pictured) forcing the platform to rise. The force of the spring tension is just enough to lift the weight of the platform and extend lip.

The ratchet pawl disengages only when the platform release ring (6) is pulled AND held. Spring tension from pawl spring causes the ratchet pawl to engage the ratchet bar when the release ring is let go.

When the platform rises to approximately 2–3 inches (51–76 mm) from its full raised height, the lip snubber spring (13) and a chain pulls the lip link (4) down. This, in conjunction with the lip assist spring (5), causes the lip linkage to push the lip out and up. The lip assist spring also helps control the amount of time required for the lip to fully fold.

IMPORTANT

When activating the leveler, always pull AND hold the platform release ring until the platform is at the full raised position. Releasing the ring while the platform is still rising may result in damage to the equipment.

To lower the platform, the operator walks out onto the platform. The platform will lower until the extended lip rests on the truck bed. If the lip did not fully extend or there is no truck at the dock, the platform will lower until one of the following conditions occur:

- Lip is resting on lip keepers (cross-traffic position).
- Lip did not fully fold causing the platform to rest on safety legs (below-dock position).
- Lip did not fully fold and safety legs are retracted, causing the platform to rest on the safety stops (full below-dock position).

To actuate the dock leveler platform, the operator pulls and holds the platform release ring (6) located in the recess at the rear of the platform. This causes ratchet pawl (7) to disengage from ratchet bar (8). With the ratchet pawl disengaged, spring tension from lift springs (18) forces the platform to rise.

NOTE: Ratchet pawl (7) and bar (8) are part of the hold-down mechanism (9)

The hold-down ratchet assembly will keep the platform at the desired position until the platform release ring is pulled again.

OPERATION

Operating Instructions

DANGER

Stay clear of dock leveler when freight carrier is entering or leaving dock area.

DO NOT raise or lower the dock leveler if anyone is under or in front of leveler.

Keep hands and feet clear of pinch points. Avoid putting any part of your body near moving parts.

Failure to follow these instructions may result in severe personal injury or death.

WARNING

DO NOT activate the dock leveler until the truck/trailer is positioned squarely against the bumpers and the truck wheels are chocked.

Never remove the wheel chocks until loading and unloading is finished and truck driver has been given permission to leave.

DO NOT use the dock leveler if the freight carrier is too high or too low.

NEVER use a fork truck or any other material handling equipment to lower the dock leveler.

DO NOT drive any equipment onto the dock leveler until platform lip is resting on the truck/trailer with at least 4 in. (102 mm) of overlap.

Always maintain a safe distance from side edges of leveler during the loading and unloading process.

NEVER attempt to walk on an unsupported lip.

NEVER allow untrained personnel to operate the dock leveler.

NEVER attempt to lift any part of the leveler by hand.

Failure to follow these instructions may result in serious personal injury or death.

WARNING

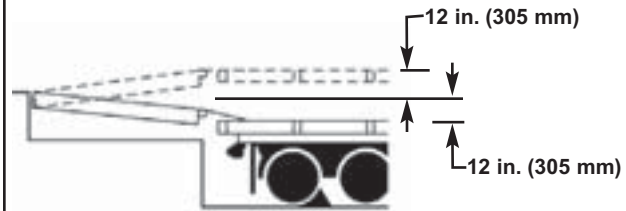

The MP-series mechanical dock leveler is designed to compensate for ± 12 in. (305 mm) of height difference between the loading dock and the truck bed. DO NOT use the dock leveler if the truck/trailer bed is more than 12 in. (305 mm) higher or lower than the dock floor.

DO NOT overload the dock leveler.

DO NOT operate any equipment while under the influence of alcohol or drugs.

DO NOT leave/store equipment or material unattended on the dock leveler.

Failure to follow these instructions may result in personal injury and/or damage to equipment.

IMPORTANT

When activating the leveler, always pull AND hold the platform release ring until the platform is at the full-raised position. Releasing the ring while the platform is still rising may result in damage to the equipment.

The dock leveler operation instructions are divided into the two methods of loading and unloading:

- For ramp loading and unloading, see Ramp Loading/Unloading Instructions on page 19.
- For end loading and unloading, see End Loading/Unloading Instructions on page 20.

Operating Instructions—Continued

Ramp Loading/Unloading Instructions

NOTE: If end unloading is required, see End Loading/Unloading Instructions on page 20.

1. Check to make sure truck/trailer is positioned squarely against dock bumpers.
2. Instruct driver to remain at the dock until the loading or unloading process has been completed.
3. Chock the truck/trailer wheels or use truck restraint if present.

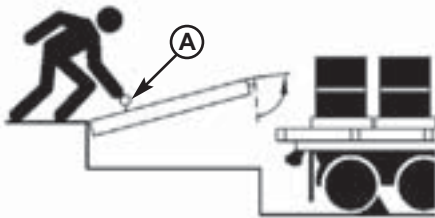

4. Raise the platform by pulling and holding the platform release ring (A).
5. Hold the release ring until the platform is at the fully-raised position and lip is fully extended.



6. Walk out onto the platform. The platform will lower until the lip rests on the truck/trailer bed.

7. Make sure that the lip is fully extended and supported on the truck/trailer along the entire width of the platform with at least 4 in. (102 mm) of lip contacting the truck bed.



8. Proceed with loading or unloading.

NOTE: If end loading is necessary, see End Loading/Unloading Instructions on page 20.

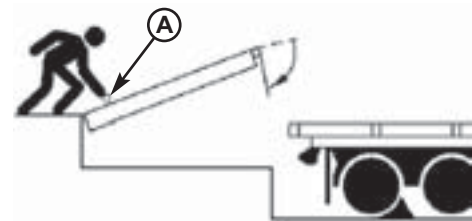

9. When the loading or unloading process has been completed, return platform to cross-traffic (stored) position as follows:
 - a. Raise the platform to the full-raised position by pulling and holding the platform release ring (A).
 - b. Lower platform by slowly walking out onto the platform allowing time for the lip to fully fold and clear the truck/trailer. Continue walking out on platform until platform lowers to the cross-traffic position (lip engages in the lip keepers).
10. Remove chocks from truck/trailer wheels or release truck restraint if used.
11. Indicate to driver that truck may leave the dock.

OPERATION

Operating Instructions—Continued

End Loading/Unloading Instructions

NOTE: End loading or unloading can be done with the dock at the cross-traffic position or below-dock position depending on the height of the truck/trailer bed.

1. Check to make sure truck/trailer is positioned squarely against dock bumpers.
2. Instruct driver to remain at the dock until the loading or unloading process has been completed, and instructed to leave.
3. Chock the truck/trailer wheels or use truck restraint if present.



End Loading/Unloading—Platform at Cross-Traffic Position.

4. If truck/trailer bed is at or above dock floor level, leave leveler at the cross-traffic position and proceed with loading or unloading. When finished, perform steps 9 and 10.

If truck/trailer bed is below the dock floor level, perform steps 5–10.

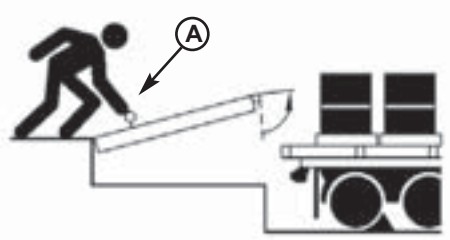

5. Pull and hold the platform release ring (A) until the platform is at the fully-raised position.

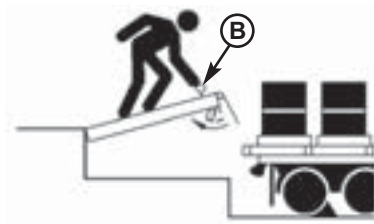

6. Slowly walk the platform down allowing enough time for the lip to fold. Just before the platform reaches the cross-traffic position, pull and hold the safety leg retract pull ring (B) (located in a recess at front of the platform). The platform will continue lowering to the full below dock position.



End Loading/Unloading—Platform at Below-Dock Position.

7. Proceed with loading or unloading.

NOTE: When end unloading is finished and additional access to the truck/trailer requires that the platform lip be extended, see Ramp Loading/Unloading Instructions on page 19 for further instructions.

8. When loading or unloading is finished, raise the platform to the full-raised position by pulling and holding the platform release ring. Slowly walk the platform down, allowing enough time for the lip to fold. The platform will lower to the cross-traffic position (lip engages in the lip keepers).
9. Remove chocks from truck/trailer wheels or release truck restraint if used.
10. Indicate to the driver that the truck may leave the dock.

Service Dock Leveler Safely

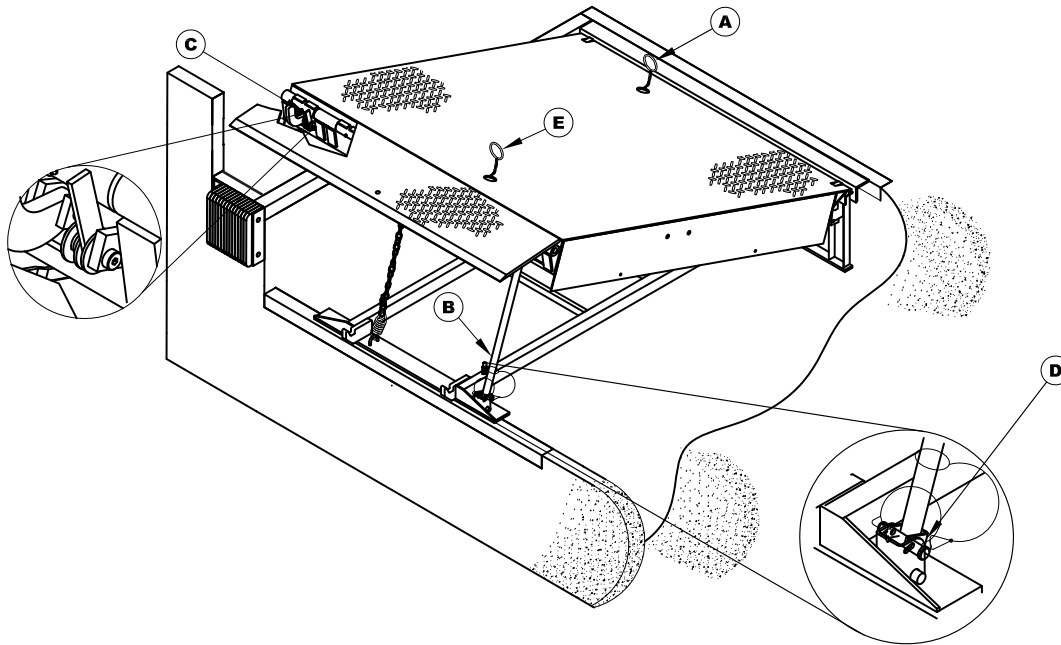

A—Platform Release Ring B—Platform Maintenance Prop C—Lip Maintenance Prop D—Prop Pin and Clip E—Safety Leg Pull Chain

WARNING

Always post safety warnings and barricade the work area at dock level and ground level to prevent unauthorized use of the dock leveler before maintenance is complete. Failure to do this may result in serious personal injury or death.

WARNING

Always stand clear of the dock leveler lip when working in front of the dock leveler. Failure to do this may result in serious personal injury or death.

WARNING

The platform maintenance prop **MUST** be in the service position when working under the dock leveler. For maximum protection, use an OSHA approved lock out tag out device, supplied by others, to lock the maintenance prop in the service position. Only the person servicing the equipment should have the key to unlock the maintenance prop.

Failure to follow these instructions may result in serious personal injury or death.

Whenever maintenance is to be performed under the dock leveler platform, support the platform with the platform maintenance prop (B).

Put the platform maintenance prop in the service (upright) position so that the prop is cradled in back of the header plate and the underside of the deck plate. Secure the platform maintenance prop in this position by inserting the pin or attaching an OSHA approved lockout device* and tagout device*, supplied by others .

Only the person servicing the equipment should have the capability to remove the lockout device. The tagout device must inform that repairs are in process and clearly state who is responsible for the lockout condition.

If maintenance requires that the lip be in the extended position, raise the lip by hand and support the lip with the lip maintenance prop (C).

NOTE: Make sure to disengage the lip maintenance prop and allow the lip to fold fully before disengaging the platform maintenance prop.

* Refer to OSHA regulation 1910.147.

MAINTENANCE

Periodic Maintenance

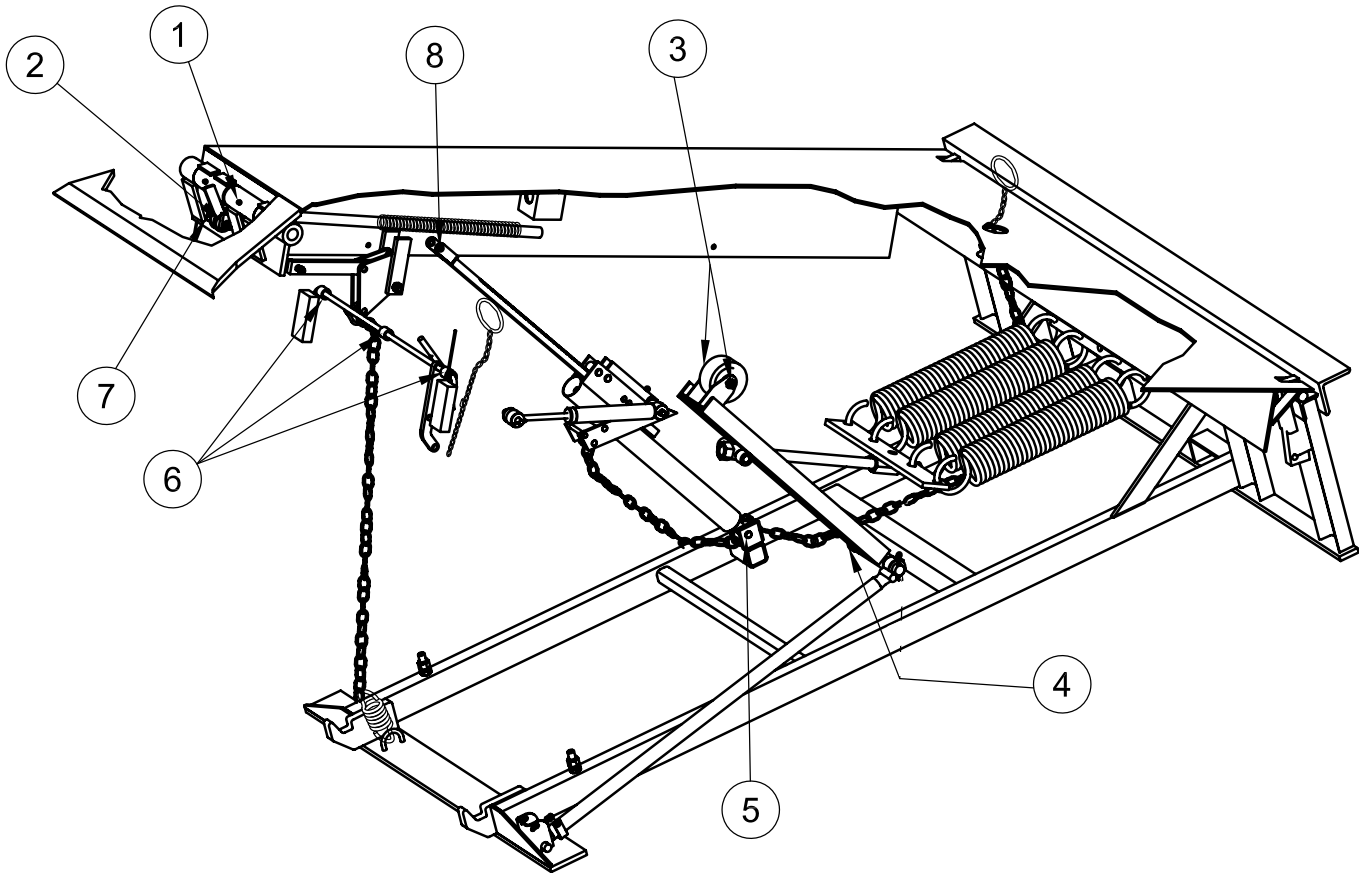

1—Lip Hinge Grease Fittings
2—Lip Maintenance Prop Pivot

4—Lift Arm Pivot
5—Hold-Down Pivot/Pulley
6—Safety Leg Linkage Pivots

7—Lip Lift Assist Pin
8—Hold Down-to-Platform Pin

WARNING

Always post safety warnings and barricade the work area at dock level and ground level to prevent unauthorized use of the dock leveler before maintenance is complete. Failure to do this may result in serious personal injury or death.

WARNING

Always stand clear of the dock leveler lip when working in front of the dock leveler. Failure to do this may result in serious personal injury or death.

WARNING

The platform maintenance prop **MUST** be in the service position when working under the dock leveler. For maximum protection, use an OSHA approved locking device to lock the maintenance prop in the service position, supplied by others. Only the person servicing the equipment should have the key to unlock the maintenance prop.

Failure to follow these instructions may result in serious personal injury or death.

Regular maintenance must be performed on a weekly and quarterly schedule.

Weekly Maintenance

- Operate the dock leveler through the complete operating cycle to maintain lubrication.

NOTE: To thoroughly inspect the platform hinge area, position the platform in the full below-dock position.

- Inspect the platform hinge and the lip hinge areas. The hinge areas must be kept free of dirt and debris. Build-up of foreign material in the hinge areas will increase wear and cause abnormal operation.

IMPORTANT

Failure to properly lubricate the dock leveler will cause abnormal operation of the leveler.

DO NOT lubricate the hold-down ratchet bar and pawl.

Quarterly Maintenance

- Lubricate the following areas with light-weight machine oil:

(2)—Lip maintenance prop pivot

(5)—Hold-down pivot/pulley

(6)—Safety leg linkage pivots

(8)—Hold down-to-platform pin

- Lubricate the following areas with white lithium grease:

(1)—Lip hinge area (inject grease into all the lip hinge grease fittings)

(3)—Lift arm roller bushing

(4)—Lift arm pivot

(7)—Lip assist pin

ADJUSTMENTS

Adjust Lift Arm Spring and Lip Assist Spring Tension

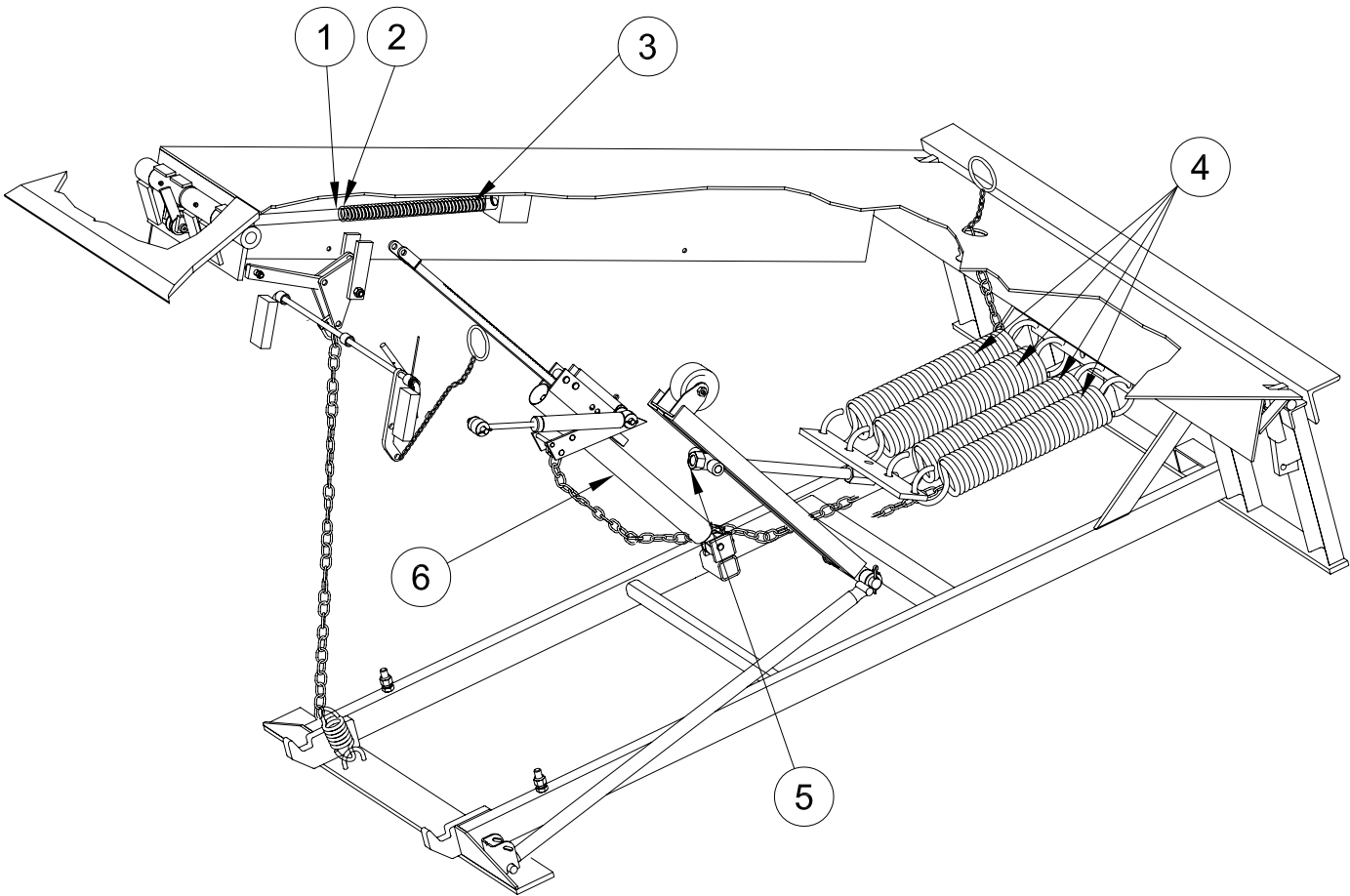

- | | | |
|------------------|---------------------|-----------------------|
| 1—Jam Nut | 3—Lip Assist Spring | 5—Lift Spring Bolt |
| 2—Adjustable Nut | 4—Lift Springs | 6—Hold-Down Mechanism |

WARNING

Always post safety warnings and barricade the work area at dock level and ground level to prevent unauthorized use of the dock leveler before maintenance is complete. Failure to do this may result in serious personal injury or death.

WARNING

The platform maintenance prop **MUST** be in the service position when working under the dock leveler. For maximum protection, use an OSHA approved locking device to lock the maintenance prop in the service position supplied by others. Only the person servicing the equipment should have the key to unlock the maintenance prop.

Failure to follow these instructions may result in serious personal injury or death.

WARNING

Always stand clear of the dock leveler lip when working in front of the dock leveler. Failure to do this may result in serious personal injury or death.

NOTE: Adjusting the tension of lift springs (4) usually requires that the lip assist spring (3) also be adjusted.

If the platform does not rise fully and/or lip does not extend fully, the lift spring tension may be set too low.

If the platform cannot be walked down or is difficult to walk down, the lift spring tension may be set too high.

WARNING

If the platform does not rise fully on its own, it may be necessary to use an external lifting device. Use a lifting device with the appropriate lifting capacity to safely raise the platform. Make sure to engage and pin the platform maintenance prop after raising the platform. Failure to do this may result in serious personal injury or death.

IMPORTANT

When using an external lifting device to raise the platform, make sure hold-down mechanism (6) is disengaged. Pull and hold platform release ring during the lifting process to avoid shearing the ratchet pawl and ratchet bar teeth.

1. Raise the platform and engage the platform maintenance prop. Pin the maintenance prop in the service position using attached pin device.
2. Adjust tension of lift springs (4) as follows:

NOTE: Use 1/2 turn increments when adjusting lift spring bolt (5). Turn clockwise to increase tension and counterclockwise to decrease tension. Check platform operation after each adjustment. Repeat until proper operation is obtained.

- To increase lift spring tension, turn lift spring bolt (5) clockwise.
- To decrease lift spring tension, turn lift spring bolt (5) counterclockwise.

3. After lift spring adjustment is completed, check operation of the lip.
 - If the lip folds before the platform can be walked down, tension of lip assist spring (3) may be set too low.
 - If the lip does not fold fully or takes too long to fold, tension of lip assist spring (3) may be set too high.
4. Adjust lip assist spring tension as follows:

NOTE: Use two-turn increments when adjusting lip assist spring (3). Check lip operation after each adjustment. Repeat until proper operation is obtained.

 - a. Loosen jam nut (1).
 - b. To increase spring compression, turn nut (2) clockwise.
 - c. To decrease spring compression, turn nut (2) counterclockwise.
 - d. Tighten jam nut.
5. Recheck operation of platform and lip. Readjust lift spring tension and lip assist spring tension until proper operation is obtained.

ADJUSTMENTS

Adjust Lip Stop Bolt

WARNING

Always post safety warnings and barricade the work area at dock level and ground level to prevent unauthorized use of the dock leveler before maintenance is complete. Failure to do this may result in serious personal injury or death.

WARNING

Always stand clear of the dock leveler lip when working in front of the dock leveler. Failure to do this may result in serious personal injury or death.

WARNING

The platform maintenance prop **MUST** be in the service position when working under the dock leveler. For maximum protection, use an OSHA approved locking device, supplied by others, to lock the maintenance prop in the service position. Only the person servicing the equipment should have the key to unlock the maintenance prop.

Failure to follow these instructions may result in serious personal injury or death.

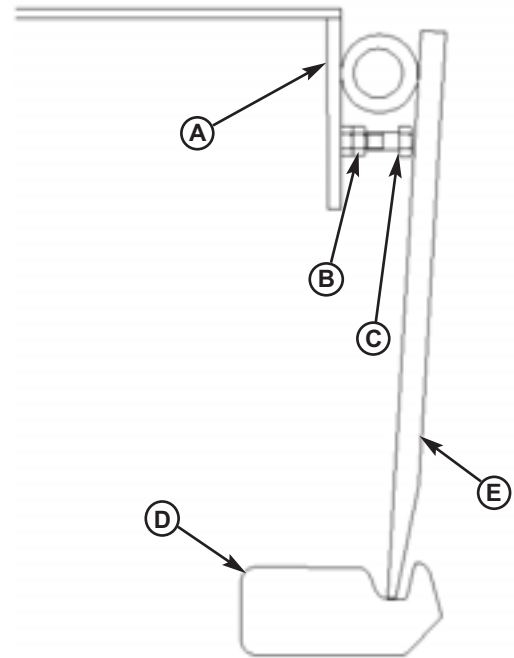

A—Platform
B—Jam Nut
C—Stop Bolt

D—Lip Keeper
E—Lip

Check that lip (E) is fully resting on the lip keepers (D) and at the lowest part of the lip keepers. If lip is not resting properly in lip keepers, perform the following adjustment.

1. Fully raise platform. Manually raise the lip and engage lip maintenance prop (not shown).
2. Loosen jam nut (B).
3. Adjust stop bolt (C) as necessary.
 - Turn stop bolt “in” (clockwise) to allow lip to fold closer to platform (A).
 - Turn stop bolt “out” (counterclockwise) to hold lip further away from platform (A).
4. Tighten jam nut (B).
5. Disengage lip maintenance prop.
6. Walk platform down to cross-traffic (stored) position.
7. Check lip position in both keepers. Repeat procedure if necessary.

Troubleshooting

 **WARNING**

Always post safety warnings and barricade the work area at dock level and ground level to prevent unauthorized use of the dock leveler before maintenance is complete. Failure to do this may result in serious personal injury or death.

 **WARNING**

Always stand clear of the dock leveler lip when working in front of the dock leveler. Failure to do this may result in serious personal injury or death.

 **WARNING**

The platform maintenance prop **MUST** be in the service position when working under the dock leveler. For maximum protection, use an OSHA approved locking device to lock the maintenance prop in the service position, supplied by others. Only the person servicing the equipment should have the key to unlock the maintenance prop.

Failure to follow these instructions may result in serious personal injury or death.

Symptom	Possible Cause	Solution
Platform does not rise.	Heavy object(s) on platform.	Remove object(s) from platform. <i>NOTE: For safety reasons, the dock leveler is designed to lift only the platform's own weight.</i>
	Disconnected or broken release chain.	Connect or replace chain.
	Dock leveler binds.	Check for visible obstructions that could cause binding. Check weather seal if equipped. If no obstructions found, call NOVA Technical Services. See cover for phone number and address.
Platform rises slowly or does not rise to the full raised position.	Heavy object(s) on platform.	Remove object(s) from platform. <i>NOTE: For safety reasons, the dock leveler is designed to lift only the platform's own weight.</i>
	Dock leveler binds.	Check for visible obstructions that could cause binding. Check weather seal if equipped. If no obstructions found, call NOVA Technical Services. See cover for phone number and address.
	Insufficient main spring tension.	Increase tension on main springs. (See Adjust Lift Arm Spring and Lip Assist Spring Tension in the Adjustments section.)
	Damaged or worn hold-down mechanism.	Clean and inspect hold-down mechanism.

TROUBLESHOOTING

Symptom	Possible Cause	Solution
Platform rises to full height, but lip does not fully extend.	Lip assist chain disconnected or broken.	Connect or replace chain.
	Insufficient main spring tension.	Increase tension on main lift springs. (See Adjust Lift Arm Spring and Lip Assist Spring Tension in the Adjustments section.)
	Insufficient lip assist force.	Increase lip assist spring compression. (See Adjust Lift Arm Spring and Lip Assist Spring Compression in the Adjustments section.)
Platform does not lower when operator walks out onto the platform.	Excessive main spring tension.	Reduce main spring tension. (See Adjust Lift Arm Spring and Lip Assist Spring Tension in the Adjustments section.)
	Damaged or worn hold-down mechanism.	Clean and inspect hold-down mechanism.
Lip folds too fast during normal walk-down.	Insufficient lip assist force.	Increase lip assist spring compression. (See Adjust Lift Arm Spring and Lip Assist Spring compression in the Adjustments section.)
	Disconnected, worn, or broken gas strut.	Inspect shock absorber. Connect or replace gas strut.
Platform does not stay down.	Entangled release chain.	Remove cause of entanglement.
	Dirt impacted in ratchet bar teeth.	Clean and inspect ratchet bar and ratchet pawl teeth. DO NOT lubricate the ratchet assembly.
	Broken or damaged ratchet assembly teeth.	Replace ratchet assembly. DO NOT lubricate the ratchet assembly.
	Disconnected or broken hold-down pivot pins.	Replace hold-down pivot pins.
	Damaged or worn hold-down mechanism.	Clean and inspect hold-down mechanism.
Lip does not fold after truck departs.	Lip hinge binding because of lack of lubrication	Inject grease into all of the lip hinge grease fittings. (See Periodic Maintenance in the Maintenance section.)
	Excessive lip assist force.	Decrease lip assist spring compression. (See Adjust Lift Arm Spring and Lip Assist Spring Compression in the Adjustments section.)

Hold-Down Mechanism

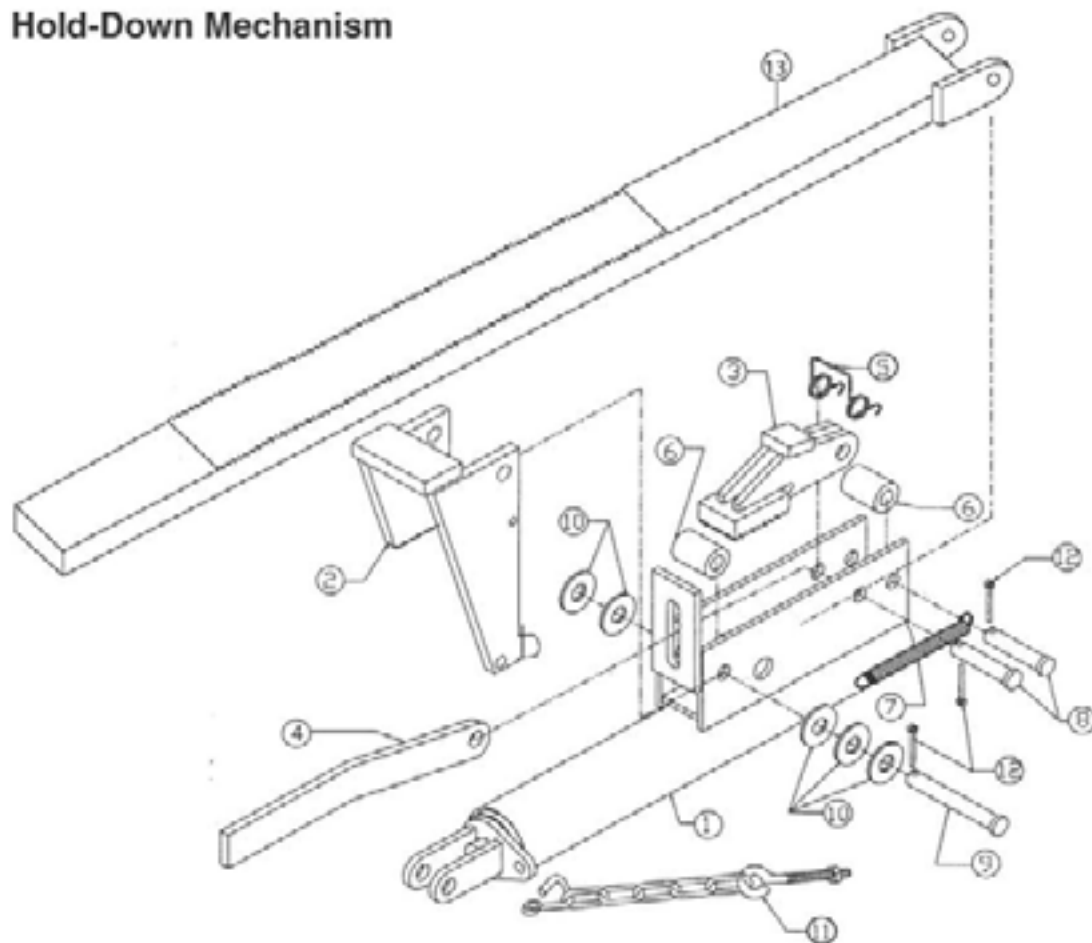

ITEM	QTY	DESCRIPTION	PART NUMBER
1	1	HOUSING	MMF3052-M1AR
2	1	RELEASE LEVER	NVS2001
3	1	PAWL	5014
4	1	HANDLE	50854
5	1	PAWL SPRING	52200
6	2	ROLLER	52702
7	1	EXTENSION SPRING	52111
8	1	2 1/4" LG CLEVIS PIN	035-006
9	1	3 1/2" LG CLEVIS PIN	52515
10	6	WASHER	000-050
11	1	CHAIN ASSY.	ARC-2
12	2	COTTER PIN	035-012
13	1	RATCHET BAR	MMF3055

PARTS

Frame Components

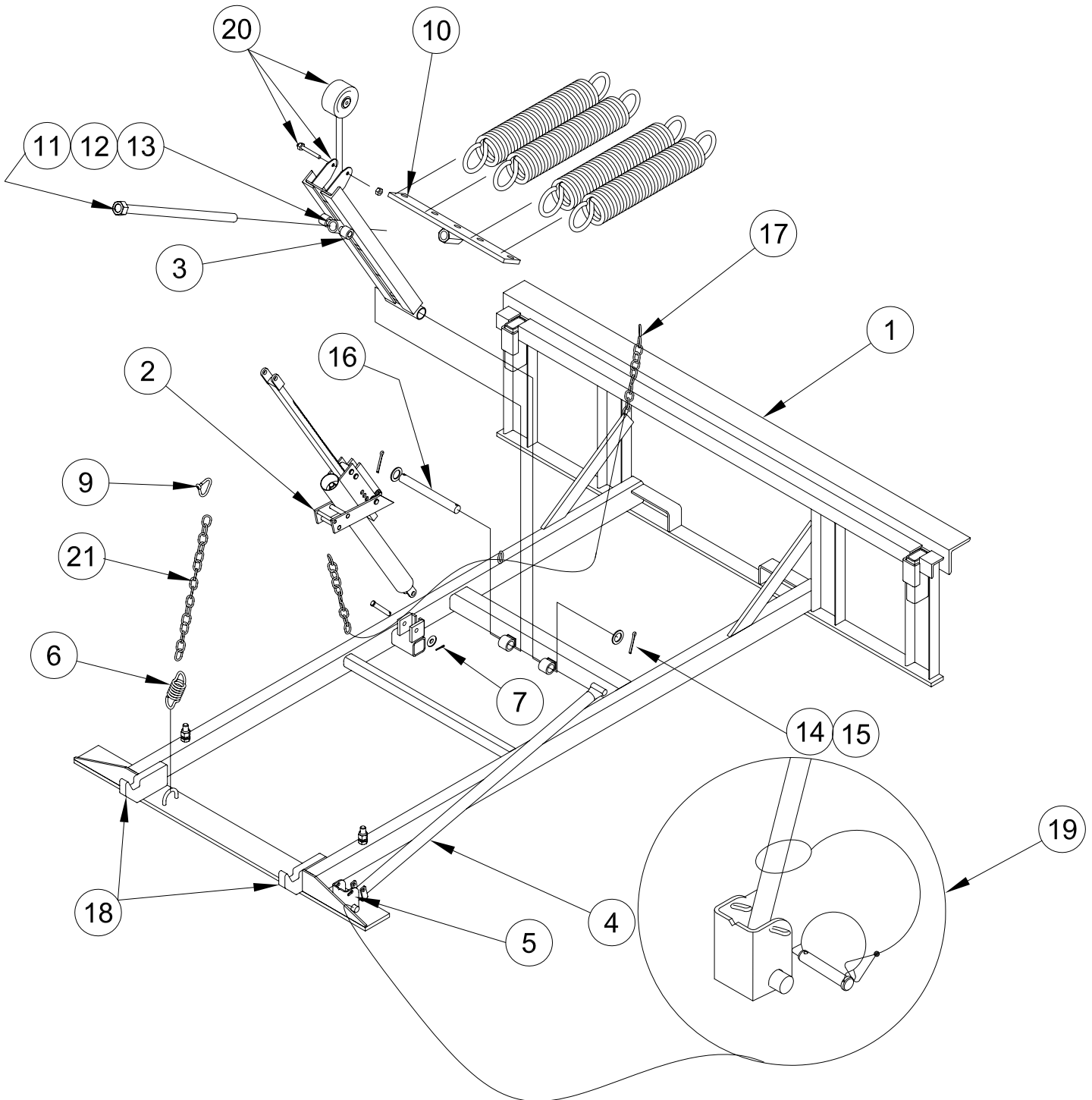

Frame Components

BASE FRAMES							
ITEM	QTY		6 FOOT		8 FOOT		10 FOOT
1		6.0 FOOT	25K/55K	6.0 FOOT	25K/55K	6.0 FOOT	25K/55K
	1	16	8435-5000	16	8435-5003	16	8435-5006
	1	18	8435-5001	18	8435-5004	18	8435-5007
	1	20	8435-5002	20	8435-5005	20	8435-5008
		6.5 FOOT		6.5 FOOT		6.5 FOOT	
	1	16	8435-5009	16	8435-5012	16	8435-5015
	1	18	8435-5010	18	8435-5013	18	8435-5016
	1	20	8435-5011	20	8435-5014	20	8435-5017
		7.0 FOOT		7.0 FOOT		7.0 FOOT	
	1	16	8435-5018	16	8435-5021	16	8435-5024
	1	18	8435-5019	18	8435-5022	18	8435-5025
	1	20	8435-5020	20	8435-5023	20	8435-5026
2	1	NVS2000AR	HOLD DOWN		SAME		SAME
3	1	DOTP-6423	LIFTER ARM 27 IN.	DOTP-6424	LIFTER ARM 25 IN (6WD 25K)	DOTP-6416	LIFTER ARM
				DOTP-6423	LIFTER ARM 27 IN(all others)		
4	1	9224-0030	MAINT PROP	9224-0031	MAINT PROP	9224-0079	MAINT PROP
5	1	9221-0028	MAINT PROP PIVOT		SAME		SAME
6	1	DOTH-2555	SPRING SNUBBER		SAME		SAME
7	3	DOTH-2356	PIN, CLEVIS		SAME		SAME
9	1	DOTH-2416	LAP LINK		SAME		SAME
10	1	DFRA-0323	PLATE SPRING	DFRA-0322	PLATE SPRING	DOTH-6875	PLATE SPRING
11				DPLA-1218	T BAR ASSY	DOTH-6425	BOLT SPRING ADJ
12	2	OTH-2218	WASHERS		SAME		SAME
13	1	DOTH-2185	NUT COUPLING		NONE		
14	2	DOTH-2222	WASHERS		SAME		SAME
15	4	DOTH-2374	PIN, COTTER		SAME		SAME
16	1	DFRA-1205	PIN LIFTER ARM		SAME		SAME
17	1	5265-0012	CHAIN 6 FOOT	5265-0013	CHAIN, 8 FOOT	5265-0014	CHAIN, 10 FOOT
18	2	8432-1129	KEEPER LIP 16		SAME	8432-1132	24 INCH PIT
	2	8432-1130	KEEPER LIP 18		SAME	8432-1133	24 INCH PIT
	2	8432-1131	KEEPER LIP 20		SAME	8432-1134	24 INCH PIT
19	1	9201-0006	PROP PIN AND CLIP		SAME		SAME
20	1	DOTH-2401	CASTER WHEEL ASSY.		SAME		SAME
21	1	DPLA-2128	CHAIN SNUBBER.		SAME		SAME

Must provide dock leveler serial number, platform size, lip size, capacity, any options and pit depth when calling or faxing orders.

PARTS

Platform Components

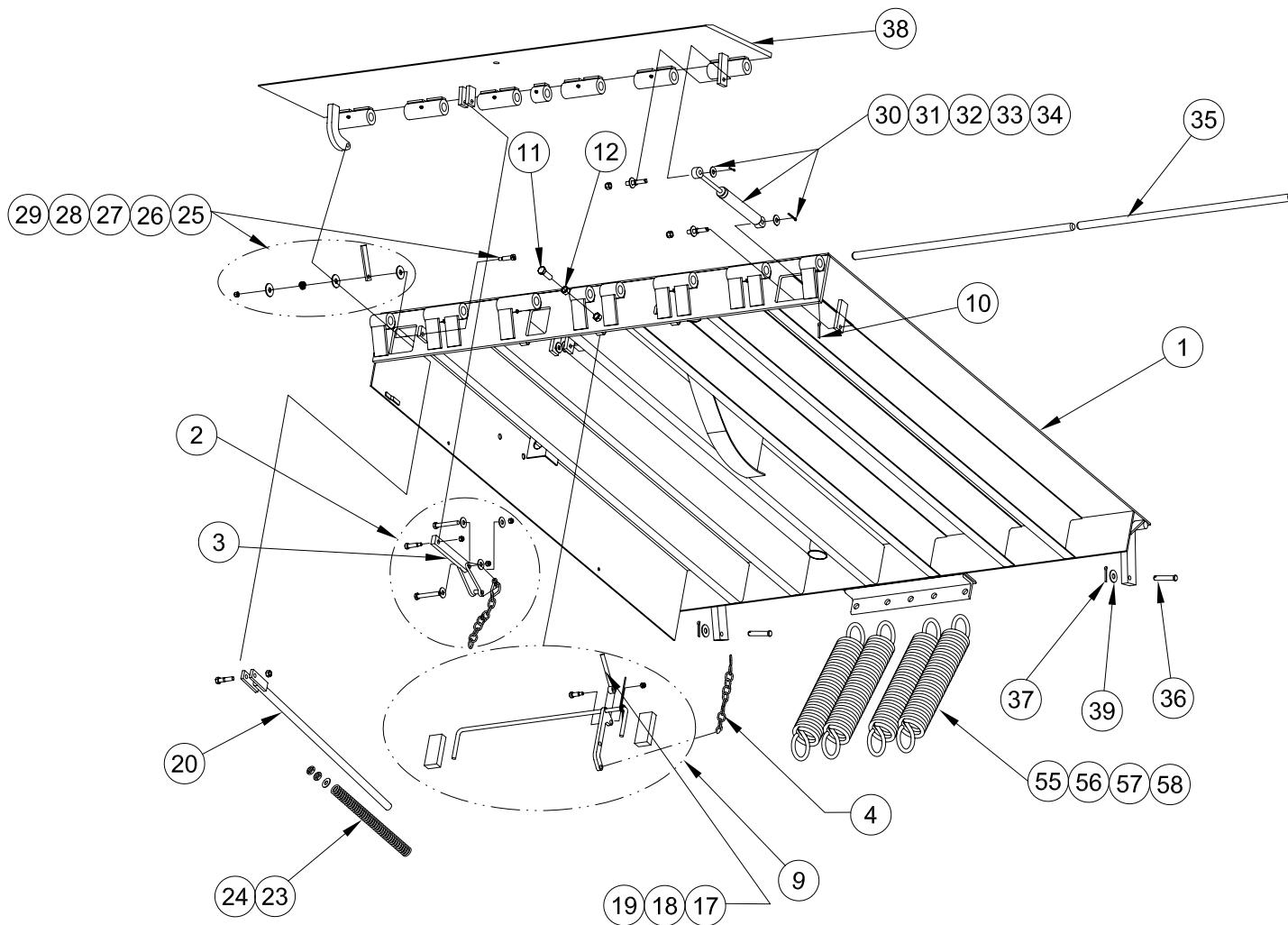

PLATFORMS													
ITEM	QTY	6 FOOT			8 FOOT			10 FOOT					
		6.0 FOOT	6.5 FOOT	7.0 FOOT	6.0 FOOT	6.5 FOOT	7.0 FOOT	6.0 FOOT	6.5 FOOT	7.0 FOOT			
1													
	1	25K	9515-5000	9515-5004	9515-5008	25K	9515-5012	9515-5016	9515-5020	25K	9515-5024	9515-5028	9515-5032
	1	30K	9515-5001	9515-5005	9515-5009	30K	9515-5013	9515-5017	9515-5021	30K	9515-5025	9515-5029	9515-5033
	1	35K	9515-5002	9515-5006	9515-5010	35K	9515-5014	9515-5018	9515-5022	35K	9515-5026	9515-5030	9515-5034
	1	40K	9515-5003	9515-5007	9515-5011	40K	9515-5015	9515-5019	9515-5023	40K	9515-5027	9515-5031	9515-5035
	1	45K	9515-5036	9515-5038	9515-5040	45K	9515-5042	9515-5044	9515-5046	45K	9515-5048	9515-5050	9515-5052
	1	55K	9515-5037	9515-5039	9515-5041	55K	9515-5043	9515-5045	9515-5047	55K	9515-5049	9515-5051	9515-5053

Platform Components

2	1	DPLA-0338	LIP BANGER ASSY.
3	2	DPLA-0341	BAR
4	1	DPLA-0353	BELOW DOCK PULL CHAIN
9	1	DPLA-0343	BELOW DOCK CONTROL ASSY.
10	2	DOTH-2382	PIN, COTTER
11	1	DOTH-2074	BOLT, HEX 5/8-11 X 2.00
12	1	DOTH-2160	NUT, HEX 5/8-11
17	1	DPLA-0360	BDC PUSH ROD ASSY
18	1	DOTH-2060	BOLT SHOULDER
19	1	DOTH-2131	LOCK NUT
20	1	DOTH-6406	LIP ASSIST ROD
23	1	DOTH-2550	SPRING ,LIP ASSIST STD (CONSULT FACTORY)
24	1	DOTH-2546	SPRING ,LIP ASSIST HEAVY (CONSULT FACTORY)
25	1	DOTP-2006	LIP PROP BAR
26	1	DOTH-2062	SHOULDER BOLT
27	1	OTH-2131	LOCK NUT
28	2	OTH-2214	WASHER
29	1	DOTH-2547	SPRING COMPRESSION
30	1	DOTH-2582	SHOCK GAS
31	1	DOTH-2351	BOLT CLEVIS
32	2	DOTH-2374	PIN COTTER
33	4	DOTH-2210	WASHER, FLAT
34	2	DOTH-2163	LOCK NUT
35		LIP SHAFTS	
	2	DPLA-2101	6.0 FOOT
	2	DPLA-2102	6.5 FOOT
	2	DPLA-2103	7.0 FOOT
36	2	DOTH-2355	PIN , CLEVIS
37	2	DOTH-2373	PIN, COTTER
39	2	2101-0079	WASHER, FLAT

38	LIPS					
	6.0 FOOT	25K	30K	35K	40/45K	55K
1	16	0595-5000	0595-5009	0595-5018	0595-5027	0595-5036
1	18	0595-5001	0595-5010	0595-5019	0595-5028	0595-5037
1	20	0595-5002	0595-5011	0595-5020	0595-5029	0595-5038
	6.5 FOOT					
1	16	0595-5003	0595-5012	0595-5021	0595-5030	0595-5039
1	18	0595-5004	0595-5013	0595-5022	0595-5031	0595-5040
1	20	0595-5005	0595-5014	0595-5023	0595-5032	0595-5041
	7.0 FOOT					
1	16	0595-5006	0595-5015	0595-5024	0595-5033	0595-5042
1	18	0595-5007	0595-5016	0595-5025	0595-5034	0595-5043
1	20	0595-5008	0595-5017	0595-5026	0595-5035	0595-5044

¹Must provide dock leveler serial number, platform size, capacity, any options and lip size when calling or faxing orders.

PARTS

Platform Components

55	SEE CHART	DOTH-2570	SPRING MAIN 6620				
56	SEE CHART	DOTH-2574	SPRING MAIN 6635				
57	SEE CHART	DOTH-2576	SPRING MAIN 6820				
58	SEE CHART	DOTH-2578	SPRING MAIN 6835				
6 FOOT LONG							
	6.0 FOOT	25K	30K	35K	40K	45K	55K
	16	(4)55	(4)55	(4)55	(4)55	(4)55	(1)55, (2)56
	18	(4)55	(4)55	(4)55	(4)55	(4)55	(1)55, (2)56
	20	(4)55	(4)55	(4)55	(4)55	(4)55	(1)55, (2)56
	6.5 FOOT						
	16	(4)55	(4)55	(4)55	(4)55	(4)55	(1)55, (2)56
	18	(4)55	(4)55	(4)55	(4)55	(4)55	(1)55, (2)56
	20	(4)55	(4)55	(4)55	(4)55	(4)55	(1)55, (2)56
	7.0 FOOT						
	16	(4)55	(4)55	(4)55	(4)55	(2)55, (2)56	(2)55, (2)56
	18	(4)55	(4)55	(4)55	(4)55	(2)55, (2)56	(2)55, (2)56
	20	(4)55	(4)55	(4)55	(4)55	(2)55, (2)56	(2)55, (2)56
8 FOOT LONG							
	6.0 FOOT	25K	30K	35K	40K	45K	55K
	16	(4) 55	(4) 57	(4) 57	(4) 57	(4) 57	(4) 57
	18	(4) 55	(4) 57	(4) 57	(4) 57	(4) 57	(4) 57
	20	(4) 55	(4) 57	(4) 57	(4) 57	(2)57, (2)58	(2)57, (2)58
	6.5 FOOT						
	16	(4) 57	(4) 57	(4) 57	(4) 57	(2)57, (2)58	(2)57, (2)58
	18	(4) 57	(4) 57	(4) 57	(2)57, (2)58	(2)57, (2)58	(2)57, (2)58
	20	(4) 57	(4) 57	(4) 57	(2)57, (2)58	(2)57, (2)58	(2)57, (2)58
	7.0 FOOT						
	16	(4) 57	(4) 57	(4) 57	(4) 57	(2)57, (2)58	(4)58
	18	(4) 57	(4) 57	(4) 57	(4) 57	(2)57, (2)58	(4)58
	20	(4) 57	(4) 57	(4) 57	(2)57, (2)58	(2)57, (2)58	(4)58
10 FOOT LONG							
	6.0 FOOT	25K	30K	35K	40K	45K	55K
	16	(8) 57	(4) 57, (4) 58	(4) 57, (4) 58	(4) 57, (4) 58	(8) 58	(8) 58
	18	(8) 57	(4) 57, (4) 58	(4) 57, (4) 58	(4) 57, (4) 58	(8) 58	(8) 58
	20	(8) 57	(4) 57, (4) 58	(4) 57, (4) 58	(4) 57, (4) 58	(8) 58	(8) 58
	6.5 FOOT						
	16	(4) 57, (4) 58	(4) 57, (4) 58	(4) 57, (4) 58	(4) 57, (4) 58	(8) 58	(8) 58
	18	(4) 57, (4) 58	(4) 57, (4) 58	(4) 57, (4) 58	(4) 57, (4) 58	(8) 58	(8) 58
	20	(4) 57, (4) 58	(4) 57, (4) 58	(4) 57, (4) 58	(4) 57, (4) 58	(8) 58	(8) 58
	7.0 FOOT						
	16	(4) 57, (4) 58	(4) 57, (4) 58	(4) 57, (4) 58	(8) 58	(8) 58	(8) 58
	18	(4) 57, (4) 58	(4) 57, (4) 58	(4) 57, (4) 58	(8) 58	(8) 58	(8) 58
	20	(4) 57, (4) 58	(4) 57, (4) 58	(4) 57, (4) 58	(8) 58	(8) 58	(8) 58

Toe Guard/Weather Seal—Optional

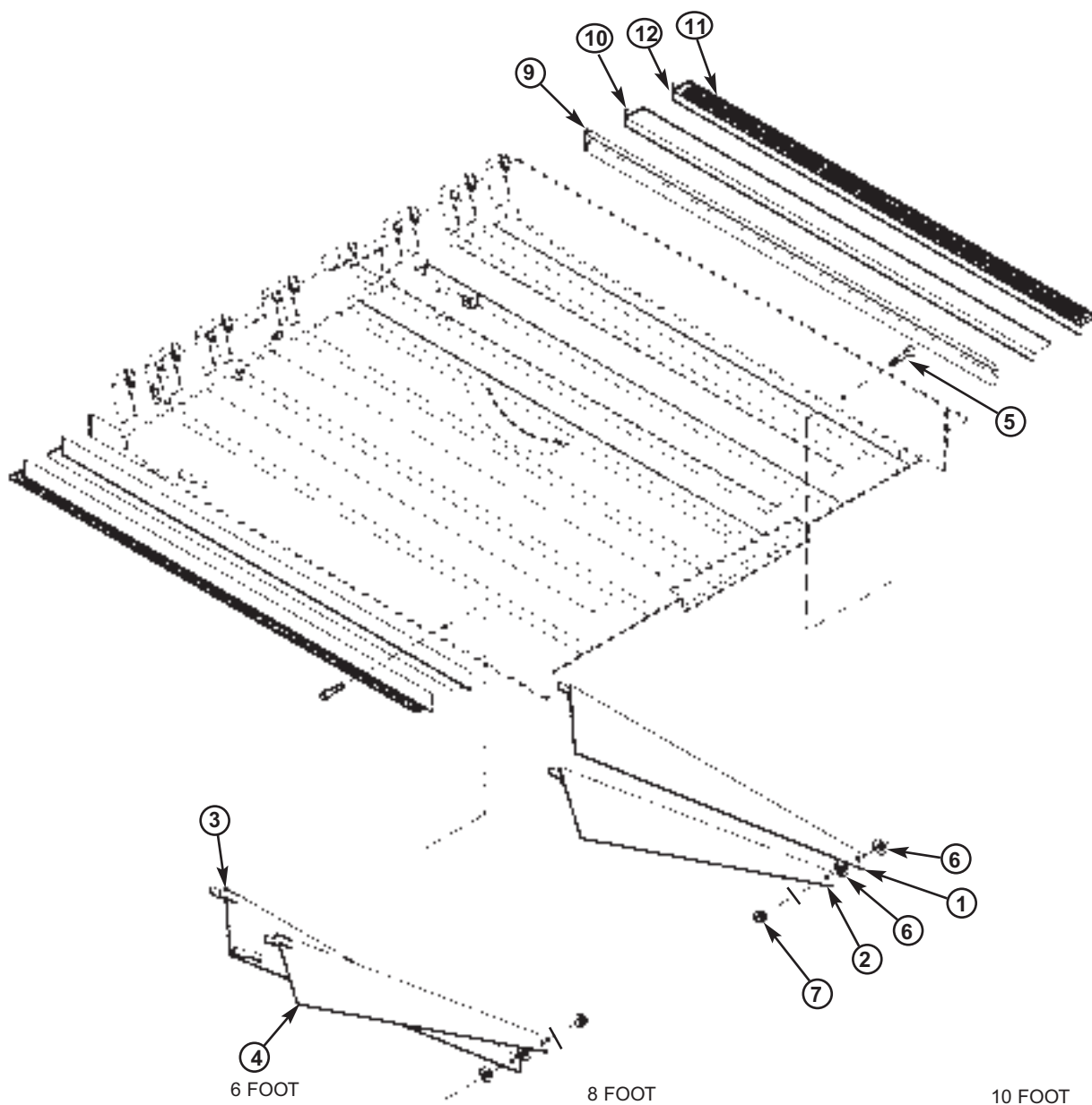

*	1	1	0014-0062	TOE GUARD LH MIDDLE	0014-0070	TOE GUARD LH MIDDLE	0014-0078	TOE GUARD LH MIDDLE
	2	1	0014-0066	TOE GUARD LH LOWER	0014-0074	TOE GUARD LH LOWER	0014-0082	TOE GUARD LH LOWER
	3	1	0014-0064	TOE GUARD RH MIDDLE	0014-0072	TOE GUARD RH MIDDLE	0014-0080	TOE GUARD RH MIDDLE
	4	1	0014-0068	TOE GUARD RH LOWER	0014-0076	TOE GUARD RH LOWER	0014-0084	TOE GUARD RH LOWER
	5	2	OTH-2041	SCREW CAP		SAME		SAME
	6	4	OTH-2207	WASHER		SAME		SAME
	7	2	OTH-2131	LOCK NUT		SAME		SAME
	*	1	DKIT-9179	FRTG COMPLETE R&L	DKIT-9180	FRTG COMPLETE R&L	DKIT-9181	FRTG COMPLETE R&L
	9	2	DOTH-2841	CHANNEL WEATHER SEAL	DOTH-2840	CHANNEL WEATHER SEAL	DOTH-2843	CHANNEL WEATHER SEAL
	10	2	DOTH-2824	T-RUBBER WEATHER SEAL	DOTH-2824	T-RUBBER WEATHER SEAL	CONSULT	FACTORY
	11	2	DOTH-2822	BRUSH WEATHER SEAL	DOTH-2822	BRUSH WEATHER SEAL	CONSULT	FACTORY
	12	2	DOTH-2821	EXTRUSION ALUM.	DOTH-2820	EXTRUSION ALUM.	CONSULT	FACTORY

This page intentionally left blank

Customer Information

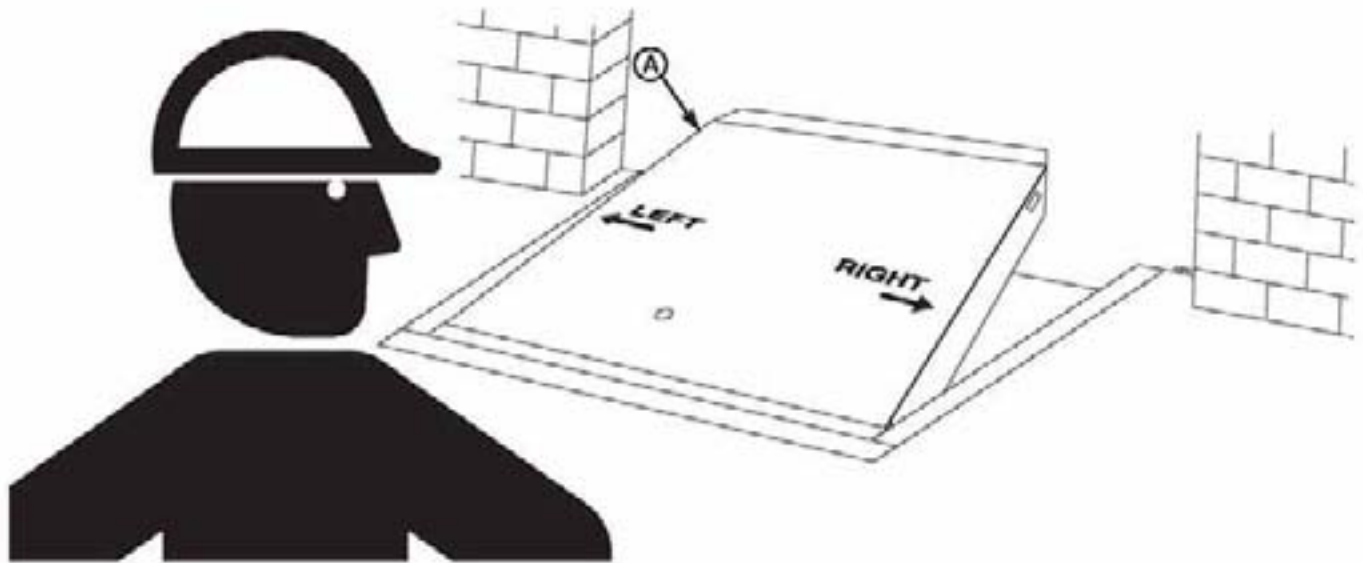

NOTE: Refer to illustration for left/right orientation of dock leveler.

The model/serial number decal (A) is located on the right platform joist near the front (lip) of dock leveler.

When you receive your NMS-series dock leveler, write down the dock leveler model and serial number in the form provided. This will help ensure safe keeping of the numbers in the event the model/serial number decal (A) becomes lost or damaged.

Also, write down NOVA's job number, the company that installed the dock leveler, and the original owner's name. This will all help to identify the specific dock leveler if more information is required.

When ordering, use part numbers and description to help identify the item ordered. Do not use "item" numbers. These are only for locating the position of the parts. Always give dock leveler MODEL NUMBER and/or SERIAL NUMBER.

For service, call or contact:
 NOVA Technology
 N90W14507 Commerce Drive
 Menomonee Falls, WI 53051
 Phone: (800) 236-7325
 Fax: (262) 502-1511

<u>Dock Leveler Information</u>	
Model	_____
Serial No.	_____
NOVA Job No.	_____
<u>Original Owner Information</u>	
Name	_____
Address	_____

<u>Installer Information</u>	
Name	_____
Address	_____

Date of Installation	_____

STANDARD PRODUCT WARRANTY

NOVA Technology warrants that its products will be free from defects in design, materials and workmanship for a period of one (1) year from the date of shipment. All claims for breach of this warranty must be made within 30 days after the defect is or can with reasonable care, be detected. In no event shall any claim be made more than 30 days after this warranty has expired. In order to be entitled to the benefits of this warranty, the product must have been properly installed, maintained and operated in accordance with all manufacturer's recommendations and/or specified design parameters and not otherwise have been subject to abuse, misuse, misapplication, acts of nature, overloading, unauthorized repair or modification, application in a corrosive environment or lack of maintenance. Periodic lubrication, adjustment and inspection in accordance with all manufacturers' recommendations are the sole responsibility of the Owner/User.

In the event of a defect, as determined by NOVA Technology covered by this warranty, NOVA Technology shall remedy such defect by repairing or replacing any defective equipment or parts, bearing the cost for the parts, labor and transportation. This shall be exclusive remedy for all claims whether based on contract, negligence or strict liability.

WARRANTY LIMITATIONS

THE ABOVE WARRANTIES ARE IN LIEU OF ANY OTHER WARRANTIES, WHETHER EXPRESSED OR IMPLIED, INCLUDING BUT NOT LIMITED TO ANY IMPLIED WARRANTY OF MERCHANTABILITY OR FITNESS FOR A PARTICULAR PURPOSE. SYSTEMS INC. AND ITS SUBSIDIARIES SHALL NOT IN ANY EVENT BE LIABLE TO ANYONE, INCLUDING THIRD PARTIES, FOR INCIDENTAL, CONSEQUENTIAL OR SPECIAL DAMAGES OF ANY KIND INCLUDING BUT NOT LIMITED TO, BREACH OF WARRANTY, LOSS OF USE, LOSS OF PROFIT, INTERRUPTION OF BUSINESS OR LOSS OF GOODWILL.

PRODUCT SPECIFIC WARRANTY "NMS" SERIES LEVELER

In addition to the "Standard Product Warranty" provided with all NOVA Products, NOVA Technology guarantees materials, components and workmanship to be free of defects for the following extended periods:

- Structural Warranty – For a period of five (5) years from the date of shipment, product will carry a prorated structural warranty. This warranty specifically applies to; the deck section, lip section, frame, rear hinge assembly and front hinge assembly only. This warranty covers structural repairs to or replacement of dock leveler at NOVA's sole discretion and expense including reasonable labor, materials, freight and travel. If NOVA determines replacement is necessary, it will provide the original purchaser with a credit toward the purchase of the new replacement NOVA product in the amount equal to the original purchase price of the warranted product F.O.B. point of manufacture, discounted on a five year straight line basis by the number of years of use prior to replacement.