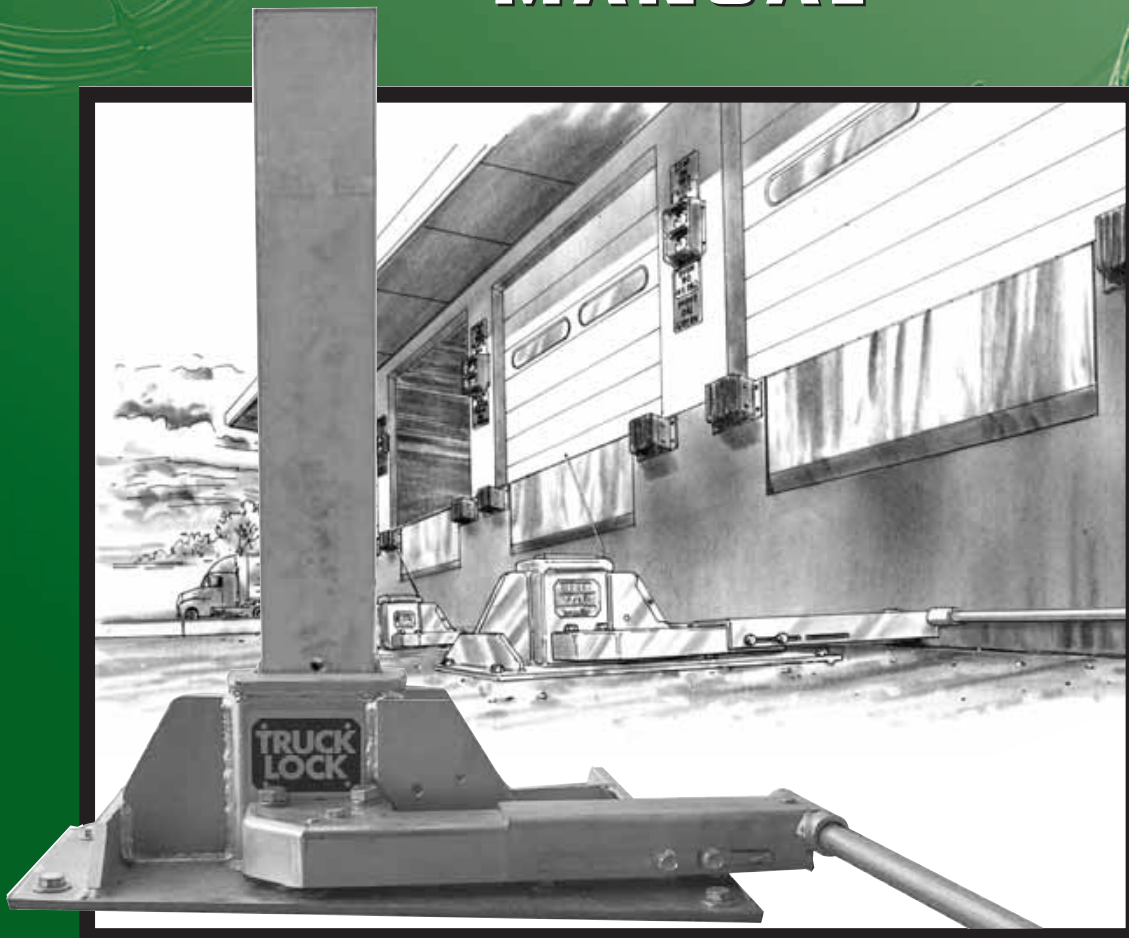


# NOVA Anchor Truck Lock™ Flange Series Manual

INSTALLATION  
PARTS &  
OWNER'S  
MANUAL



**NOVA**  
**TECHNOLOGY**  
**INTERNATIONAL, LLC.**

CATALOG NO. AFO4

# **SAFETY WARNINGS:**

## **Lockout/Tagout Procedures**


The Occupational Safety and Health Administration (OSHA) requires, in addition to posting safety warnings and barricade the work area (including, but not limited to, trucking office and loading docks), that the power supply and air supply, if applicable, has been locked in the OFF position or disconnected. It is mandatory that an approved lockout device is utilized. The proper lockout procedure requires that the person responsible for the repairs is the only person who has the ability to remove the lockout device.

In addition to the lockout device, it is also a requirement to tag the power control and air control, if applicable, in a manner that will clearly not that repairs are under way and state who is responsible for the lockout condition. Tagout devices have to be constructed and printed so that exposure to weather conditions, or wet and damp locations, will not cause the tag to deteriorate or become unreadable.


Nova Technology does not recommend any particular lockout device, but recommends the utilization of an OSHA approved device and procedures (refer to OSHA regulation 1910.147). Nova Technology also recommends the review and implementation of an entire safety program for the Control of Hazardous Energy (Lockout/Tagout). These regulations are available through OSHA publication 3120.

 **DANGER**

This is the highest level statement. Failure to follow the listed instructions will most likely result in severe injury or death.

 **CAUTION**

The statements used with this level of warning deal with a safe operating procedure. If the procedure is ignored, the possibility of personal injury may exist.

 **WARNING**

This is a statement of serious hazard. Failure to follow the listed instructions could place the individual at risk of serious injury or death.

**IMPORTANT**

Important is used to draw attention to a procedure that needs to be followed to prevent machine damage.



# INTRODUCTION



## **The NOVA Technology Anchor Truck Lock™ Flange Series & Traffic Monitoring System,**

when properly installed and operated, offers the user substantially improved dock safety and efficiency. Its design is the result of many years of experience with loading dock operation.

It features an easy to read inside light system for the dock attendant, a simple "STOP & GO" outside light system for the truck driver, and a restraining device to discourage premature or unexpected

truck departure. In addition, the optional Truck Monitor System alerts the dock supervisor to truck arrivals, departures and restraint use.

Read and follow all installation and operating instructions. Be certain to read and understand all caution statements in this booklet as well as all warning labels on the equipment. Be sure all dock attendants are properly trained in the system's function and operation.

Perform periodic inspection to insure there are no worn or damaged parts which could result in equipment failure and/or personal injury.

## INDEX

INTRODUCTION .....	PAGE 1
ARRANGEMENT AND FUNCTION OF MAJOR COMPONENTS .....	PAGE 2-3
INSTALLATION INSTRUCTIONS .....	PAGE 4-19
GENERAL MAINTENANCE .....	PAGE 20
ELECTRICAL CHECK LIST .....	PAGE 20
WIRING DIAGRAM .....	PAGE 21
ILLUSTRATED PARTS LIST .....	PAGE 22-26

# WARRANTY

NOVA TECHNOLOGY INT'L, LLC. warrants the NOVA ANCHOR TRUCK LOCK™ FLANGE SERIES and TRUCK MONITOR™ to be free of defects in material or workmanship under normal use for a period of one year from the date of shipment. This warranty does not cover any failure to properly maintain the product. This warranty is the only one given by NOVA TECHNOLOGY INT'L, LLC. and is in lieu of all guarantees and warranties expressed or implied by anyone other than NOVA TECHNOLOGY INT'L, LLC. including those of fitness for a particular purpose and merchantability. In order for warranty claims to be honored the products must have been properly installed, maintained, and operated within their intended function and not otherwise abused.

If your NOVA ANCHOR TRUCK LOCK™ FLANGE SERIES and TRUCK MONITOR™ is defective in material or workmanship and you notify NOVA TECHNOLOGY INT'L, LLC. within one year of the date of shipment, NOVA TECHNOLOGY INT'L, LLC. will, at its' option, repair or replace the defective component(s) at no cost to you.

NOVA TECHNOLOGY INT'L, LLC. will not be responsible for or pay for loss of time, inconvenience, loss of the use of the product, or property damage caused by this product or its failure to work, or any other incidental or consequential damages.

NOVA TECHNOLOGY INT'L, LLC. reserves the right to change specifications or make product improvements without notice or obligation.



### CAUTION

**Be sure that installation is performed only by qualified personnel and that electrical hook-up is performed by a qualified electrician.**

HELLO!  
THIS IS  
IMPORTANT!



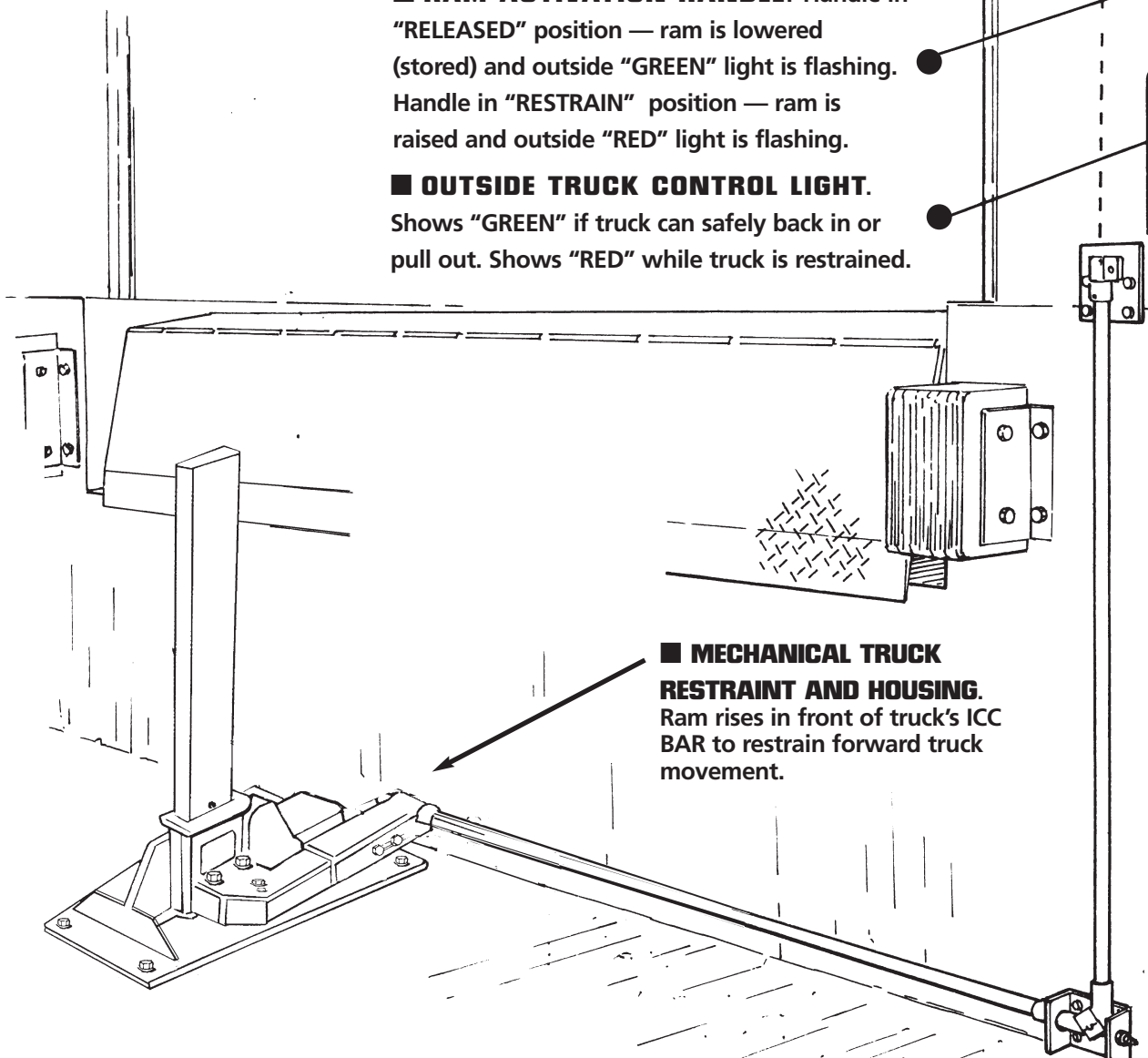
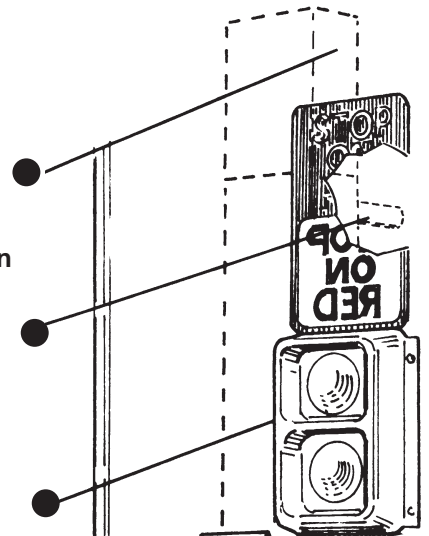
*This view* shows typical arrangements and functions of major components for the **NOVA Anchor Truck Lock™ Flange Series**

- Review Distributors' survey sheet
- Verify that the Data Corresponds to your job site requirements

■ **INSIDE LIGHT.** "RED" indicates that it is not safe to enter the truck. "GREEN" indicates that the truck has been restrained.

■ **RAM ACTIVATION HANDLE.** Handle in "RELEASED" position — ram is lowered (stored) and outside "GREEN" light is flashing. Handle in "RESTRAIN" position — ram is raised and outside "RED" light is flashing.

■ **OUTSIDE TRUCK CONTROL LIGHT.** Shows "GREEN" if truck can safely back in or pull out. Shows "RED" while truck is restrained.



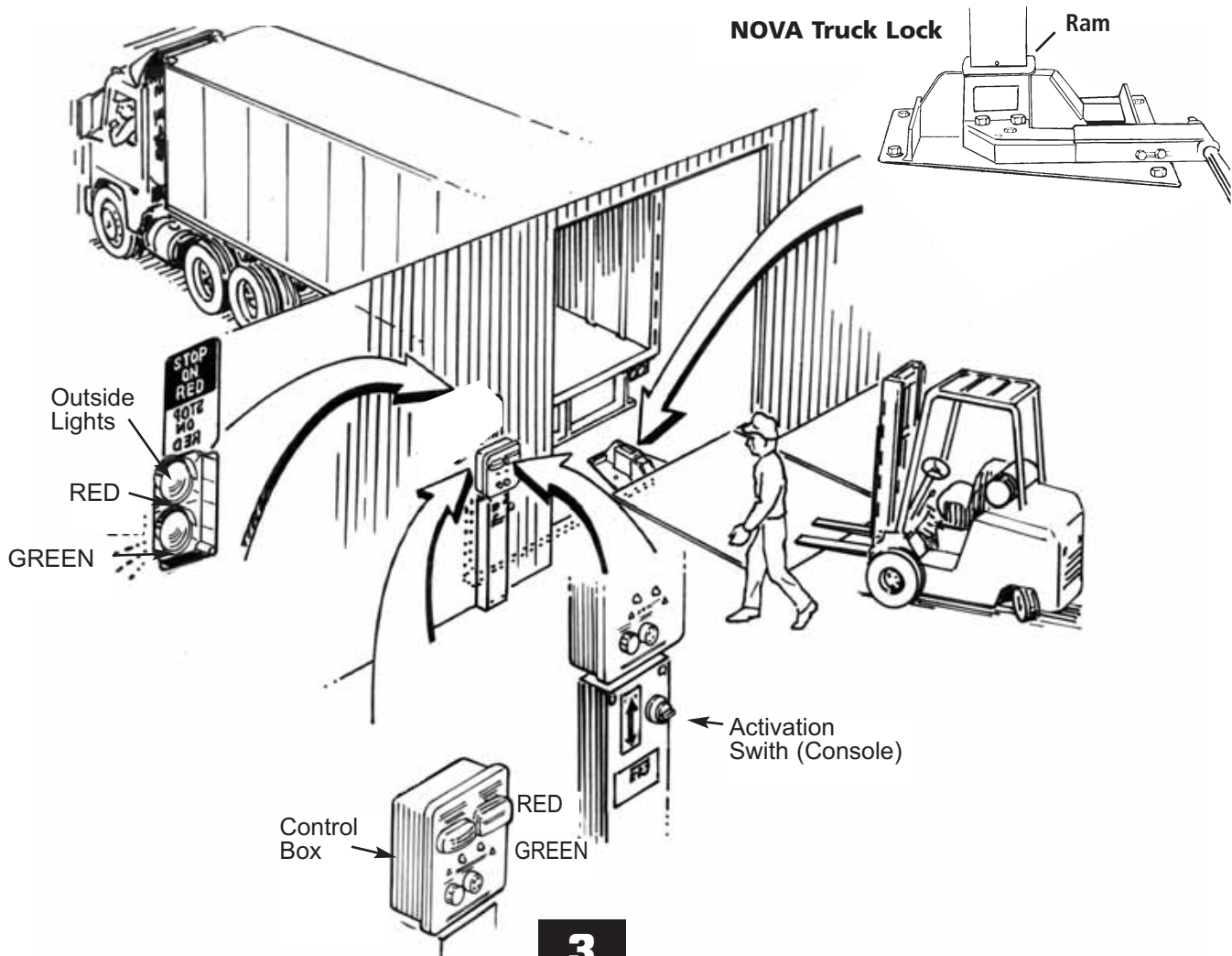
■ **MECHANICAL TRUCK RESTRAINT AND HOUSING.** Ram rises in front of truck's ICC BAR to restrain forward truck movement.

# NOVA ANCHOR TRUCK LOCK™ Flange Series Restraint Sequence

MODELS	ALL	ALL	ALL
CONDITIONS AT LOADING DOCK	RED/GREEN OUTSIDE LIGHTS	RED/GREEN INSIDE LIGHTS	ACTIVATION HANDLE/SWITCH
<ul style="list-style-type: none"> <li>•TRUCK ARRIVES</li> <li>•RAM IS LOWERED</li> </ul>	FLASHING GREEN	FLASHING RED	RELEASED
<ul style="list-style-type: none"> <li>•TRUCK IS IN &amp; RESTRAINED LOADING/ UNLOADING</li> <li>•RAM IS RAISED</li> </ul>	<b>FLASHING RED</b>	<b>CONSTANT GREEN</b> *	<b>RESTRAINED</b>
<ul style="list-style-type: none"> <li>•TRUCK IS IN &amp; LOADING/ UNLOADING IS COMPLETED</li> <li>•RAM IS LOWERED</li> </ul>	FLASHING GREEN	FLASHING RED	RELEASED

\*If ram's upper movement is restricted by a bent ICC bar or other obstruction, the outside "Red" light will flash indicating to the truck driver that it is not safe to pull out. Inside, the Audible Alarm will sound and both inside lights will flash alternately warning the dock attendant that an alternate method for restraining the vehicle is needed.

Pressing the Silence button will silence the alarm and the interior lights will continue to flash alternately. Once loading or unloading is complete, the dock attendant will depress and hold the silence button to reset the outside light. Once the truck has left the dock, it is necessary to completely cycle the restraint to reset all the lights.



# INSTALLATION INSTRUCTIONS

Every installation should be a show piece and potential customer reference.  
Please follow these instructions and the info on the survey sheet.

## STANDARD SUPPLIES (per unit) furnished by INSTALLER.

- (28) 1/4" Truss Head Concrete Fasteners
- 3/4" Thinwall Conduit — 20 ft. (Activation Cable Run)
- 1/2" Thinwall Conduit — 20 ft. (Truck Sensor Run)
- 1/2" Conduit Elbows (Two) (Truck Sensor Run)
- 1/2" Wall Clips (for conduit) (Truck Sensor Run)
- 2 quarts (8 cups) of Nova Juice-E



Nova Technology requires NOVA Juice-E to be used on all new truck restraints. Failure to follow instructions will result in a voided warranty.

### ! WARNING

Concrete driveway has to be a Min. 6" thick at min. 4000 PSI and be crack free within a 20" radius from center of 10" hole. An expansion joint between drive and building wall is acceptable.

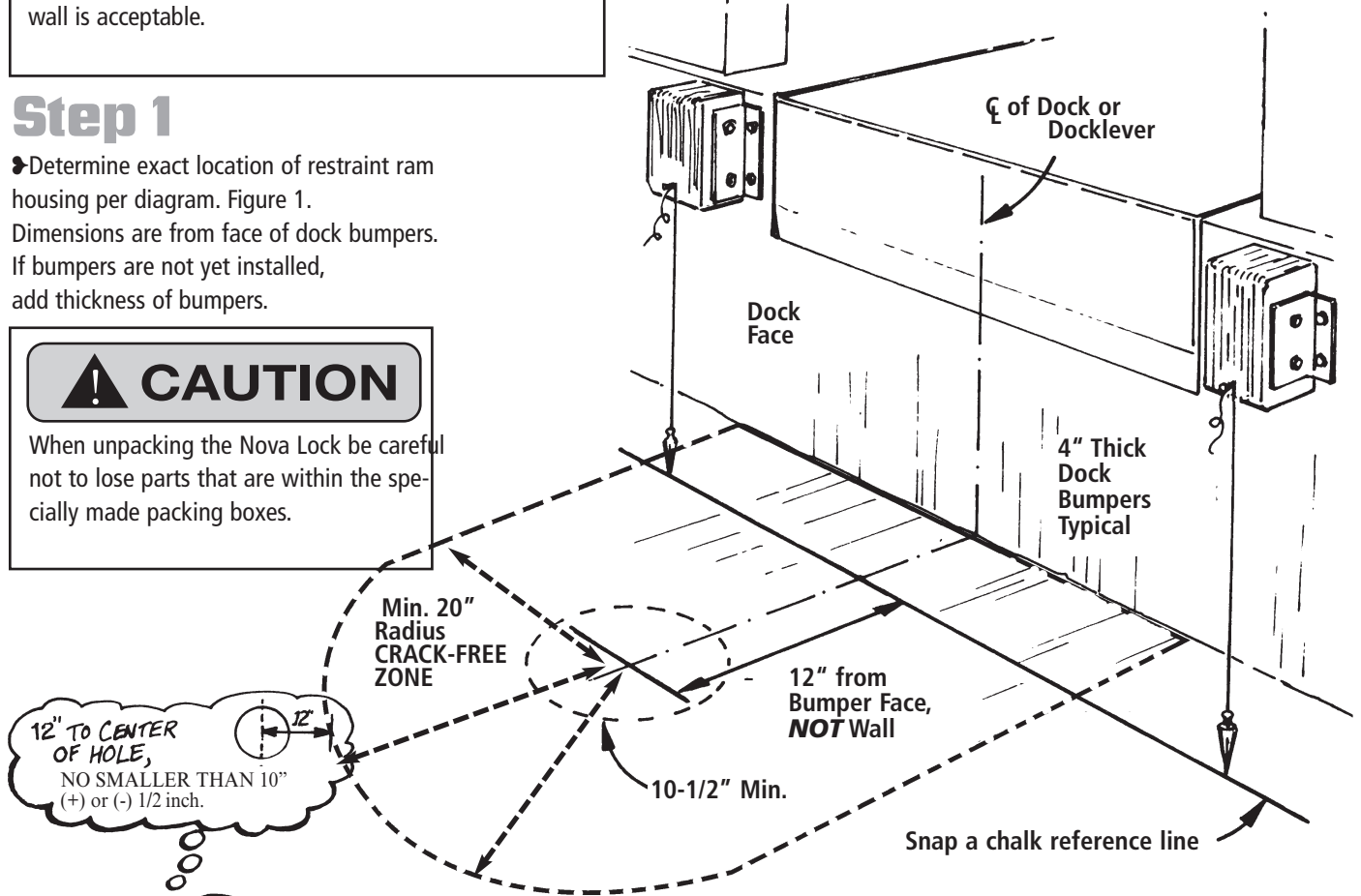
## Step 1

- Determine exact location of restraint ram housing per diagram. Figure 1. Dimensions are from face of dock bumpers. If bumpers are not yet installed, add thickness of bumpers.

### ! CAUTION

When unpacking the Nova Lock be careful not to lose parts that are within the specially made packing boxes.

Figure 1



12" TO CENTER OF HOLE,  
NO SMALLER THAN 10"  
(+) or (-) 1/2 inch.

Min. 20"  
Radius  
CRACK-FREE  
ZONE

12" from  
Bumper Face,  
NOT Wall

10-1/2" Min.

Snap a chalk reference line

**NOTE:** Drawing is NOT to scale.





## CAUTION

**IMPORTANT:** Remember Dimension from Back Edge of Ram to Bumper Face should be 10".



## WARNING

Use (7) 5/8x 5" orange tip wedge bolt. Wedge bolt is a heavy duty self tapping anchor. Meets AISI 1020/1040 carbon steel. Blue tip wedge bolts are not allowed. Ref. Power Fasteners, Inc. Wedge Bolt #7221. Nova P/N 40-0-112.

## Step 2

- ✦ Core drill (auger, posthole digger, etc.) a 10" diameter hole minimum of 30" deep.
  - ✦ Locate Flange housing sheath (see Fig. 2) and backfill with housing sheath cover in place. Make sure housing sheath bottom is 30" from top of concrete surface.
  - ✦ Place housing in sheath and insert orange tip wedge bolts. To insert wedge bolt, drill a 5/8" hole through concrete in first location. Clean out hole with compressed air. Drive wedge bolt into prepared holes until clamping the mounting plate to concrete. Do not exceed 75 ft. lbs. of torque. Drill second hole and clean out hole with compressed air, and insert bolt #2. Drill remaining 5 holes and clean out in the same manor.
  - Insert remaining (5) self tapping anchors and tighten to no more than 75 ft-lbs. of torque.
- DO NOT** insert a wedge bolt in any holes in which reinforcing rod is encountered. If rebar is encountered, use a 5/8" dia. x 5" long Powerbolt. (1) Power bolt is included with each restraint. Consult factory for more information. 1-800-236-7325.

## IMPORTANT

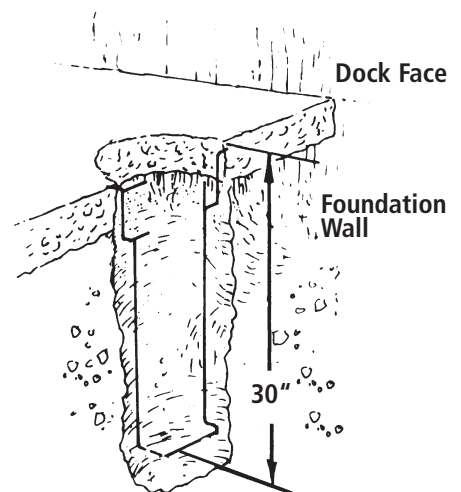
Be sure there are no obstructions on outside of building which would interfere with cable run between control console and ram housing. Position control console so that activation cable clears dock bumpers. Also be sure that there is adequate clearance for future installation of dock seals or shelters. See Figure 3.

## Step 3

- Remove cover from control console by removing four 3/8"x1/2" bolts. See Figure 4.
- If metal building support is required as per survey sheet, follow those instructions for correct installation.

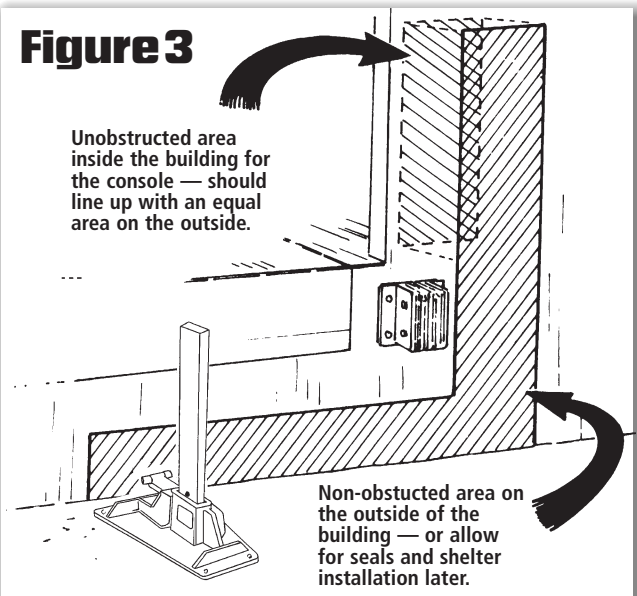
### Figure 2

#### CUTAWAY SECTION FOR CONCRETE

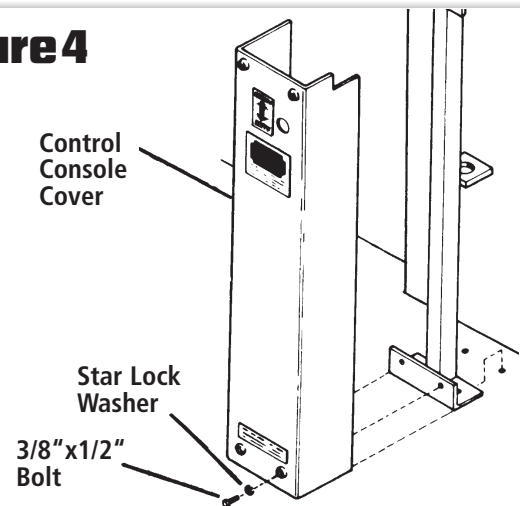


### Figure 3

Unobstructed area inside the building for the console — should line up with an equal area on the outside.



### Figure 4



## Step 4

•Temporarily place control console (with cover removed) against inside wall in desired location. Mark the four mounting holes for the console (two on wall and two on floor) as well as the 1" diameter cable exit hole. See Figure 5.

### IMPORTANT

GET THIS PART RIGHT TO AVOID CABLE RUBBING BETWEEN PULLEYS.

1. CABLE MUST RUN ON PULLEYS.
2. CABLE MUST RUN LINE OF SIGHT BETWEEN PULLEYS.
3. CABLE MUST NOT RUB ON WALL MATERIAL.

## Step 5

•First, drill the 1" diameter cable exit hole through the wall from the inside at the location marked in Figure 5.

Replace bracket and check alignment of the 1" hole per Figure 5— then drill mounting holes.

**NOTE:** To prevent outside concrete wall from chipping, drill a 1/2" pilot hole first. If into a block wall, loose insulation, etc., sleeve the hole with a section of 3/4" conduit.

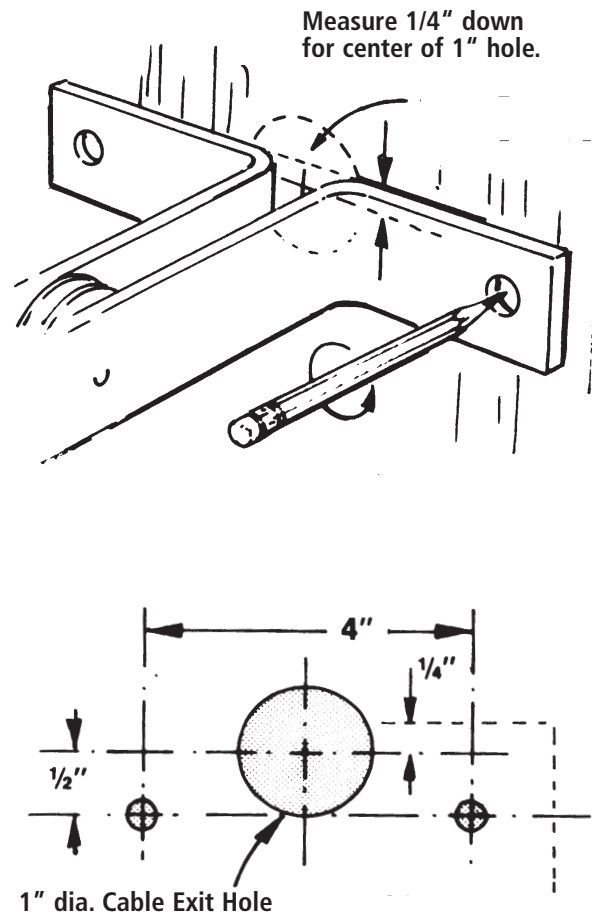
## Step 6

•Replace console pole and check alignment of the 1" hole per Figure 5. Then drill mounting holes. Mount control console on inside of building wall.

### NOTE:

Use truss head expansion bolts, toggle bolts or through bolts as appropriate. Bolts and fasteners supplied by installer.

**Figure 5**



## Step 7

- Mount upper outside pulley to exterior wall, being sure top of pulley aligns with center of 1" hole through wall. See Figure 6 and note regarding anchors above.

## Step 8

- Route cable through side extension bracket, and bolt side extension bracket to housing as shown in Figure 7. Route cable through tail section and bolt tail section to the side extension bracket as shown in Figure 7.

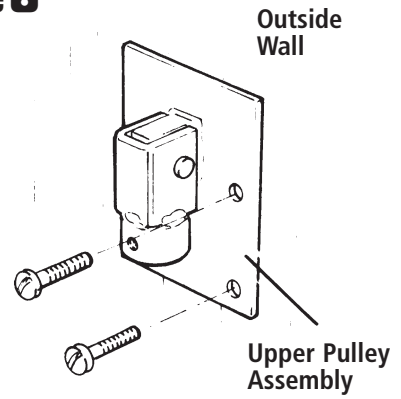
### NOTE:

Recessed building wall or dock foundation wall may require a special bracket as per your survey sheet.

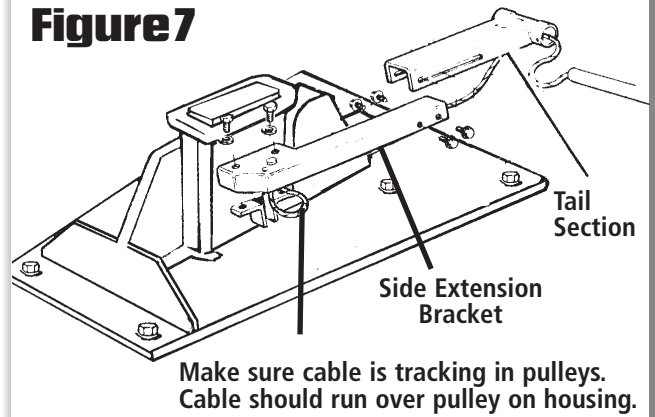
## Step 9

- Mount lower pulley swivel assembly to foundation directly beneath upper pulley assembly. In northern climates, where driveway heaving (freezing) is possible, the lower pulley swivel bracket may be installed 2-3" above the drive. See Figure 8.

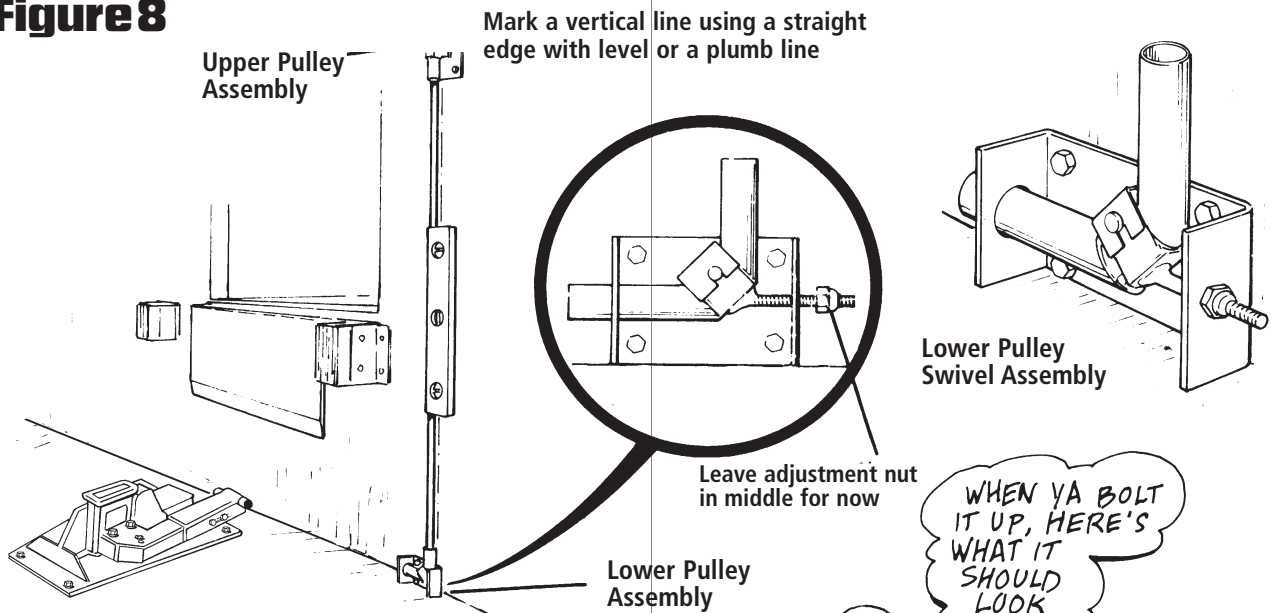
### Figure 6



### Figure 7



### Figure 8



# IMPORTANT

## Step 10

- Remove ram from housing and carefully pour in 2 quarts (8 cups) of Nova Juice-E. See figure 9.

## Step 11

- Measure distance between conduit collar on upper pulley bracket and conduit collar on lower pulley swivel bracket and add 2 - 3/4". Cut a piece of 3/4" thin wall conduit to this length. See Figure 10.

## Step 12

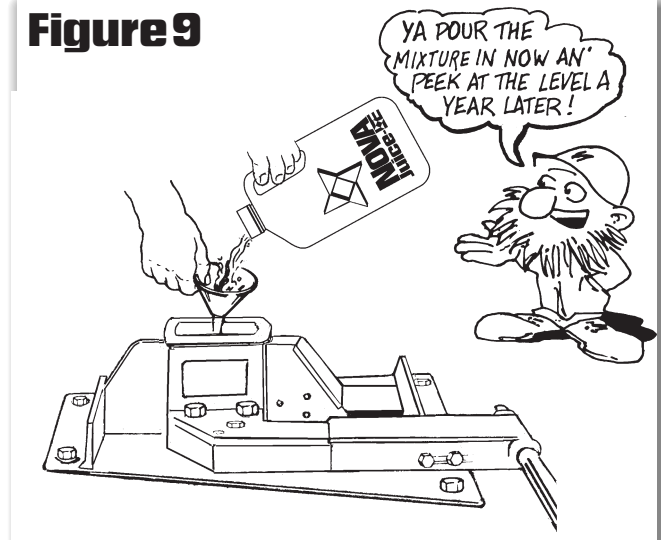
- Measure distance from conduit collar on lower pulley to conduit collar on ram housing assembly and add 2-3/4". Cut 3/4" thin wall conduit to length as above. Slide end into tube on lower pulley. Thread cable through lower and upper pulley assemblies.

Allow free cable end to stick out of conduit at top pulley. Do not attempt to feed through building wall at this time. Slide end of conduit into conduit collar on ram housing and secure with set screw. See Figure 10.

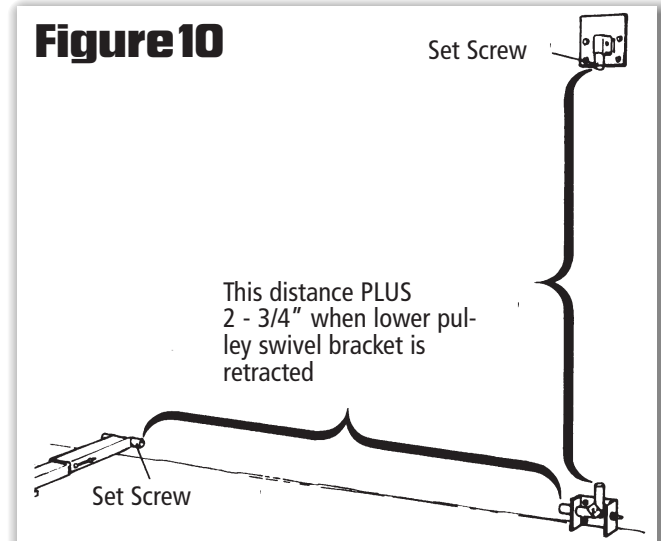
## Step 13

- Route ram cable around top of upper outside pulley, into building through hole in wall, and over the pulley between wall bracket on control console. See Figure 11.

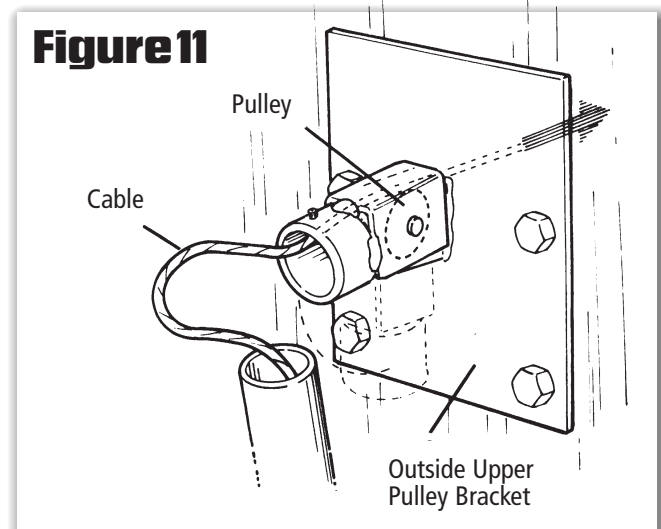
**Figure 9**



**Figure 10**



**Figure 11**



# THE FOLLOWING SECTION

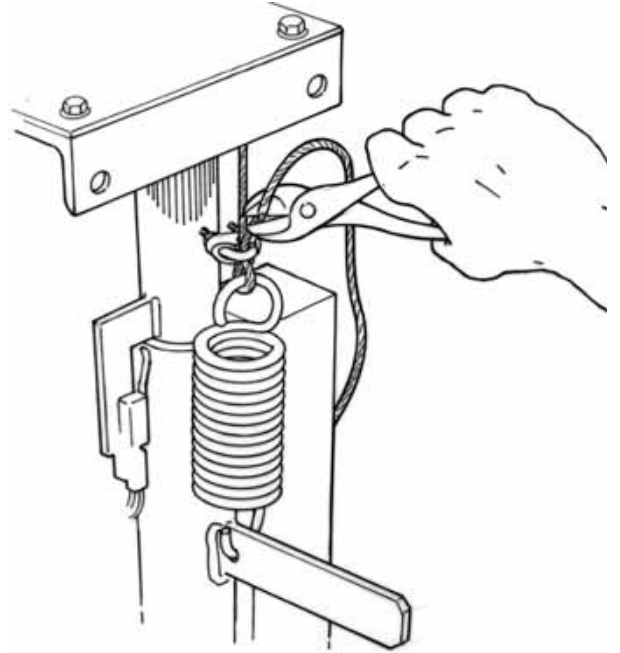
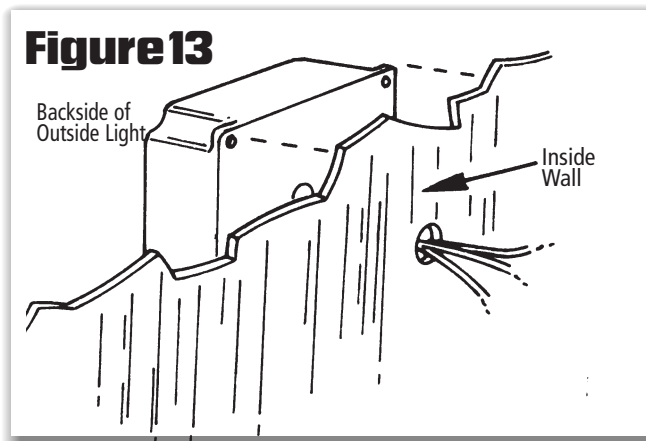
**PAGES 9-13 OF THIS MANUAL ARE FOR INSTALLATION OF  
MANUAL TRUCK RESTRAINTS (MODELS 100FM, 101FM).**

## Step 13M

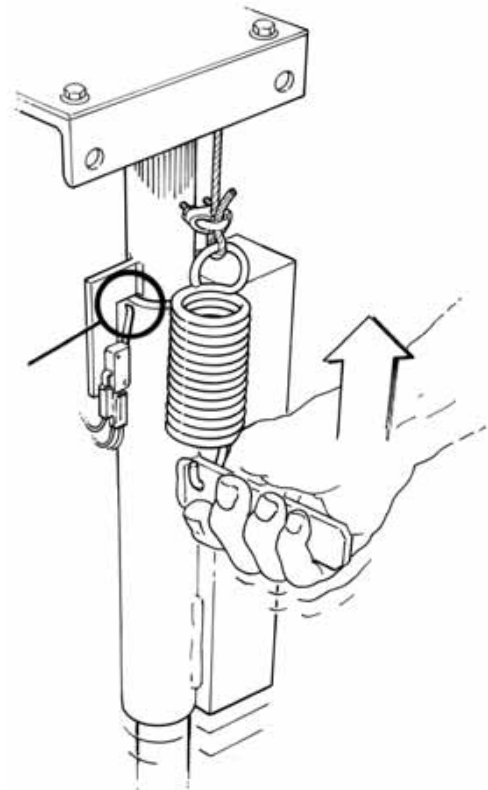
- Raise handle to full up position. Make sure upper limit switch lever is contacting Activation Handle Tube. Pull cable tight and attach to spring using cable bolt and bracket. Run excess cable down center of spring, exiting on right side of handle. Cut off cable flush with bottom of spring. See Figure 12.

## Step 14M

- Determine location of outside light on exterior of building. Light must be on truck driver side of dock door (right side when facing dock from outside) and 8' above surface of drive. Be sure location of light will not interfere with the future installation of dock shelters or seals. Drill hole through wall at approximate center of light. Feed wire from light through hole in wall and affix light to wall. See Figure 13.



**Figure 12**



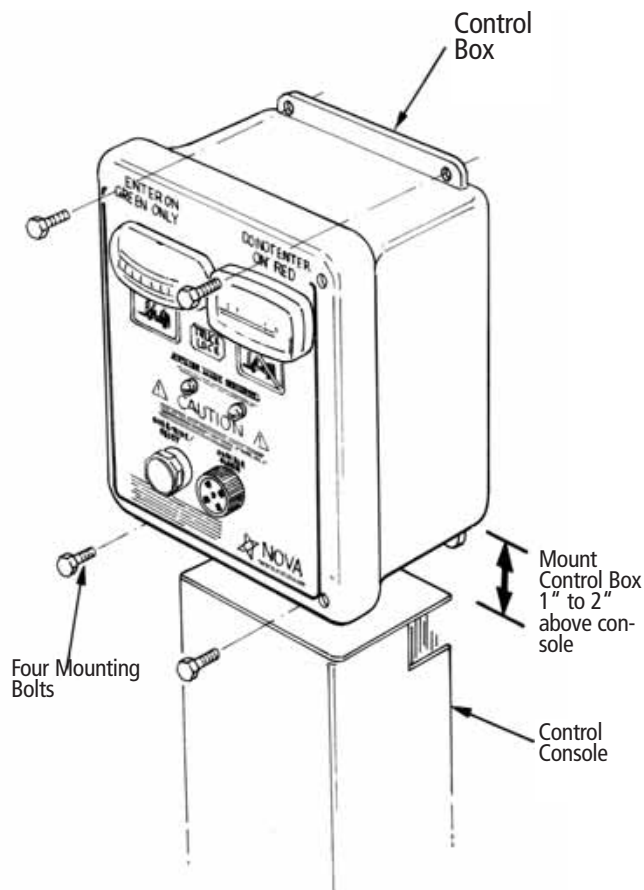
## Step 15

- Mount control box to wall 1" to 2" above console using fasteners supplied by installers.

### ⚠ CAUTION

All control and lighting circuits are low voltage. Installation of 115V grounded supply circuit must conform to local electrical codes and customer specifications.

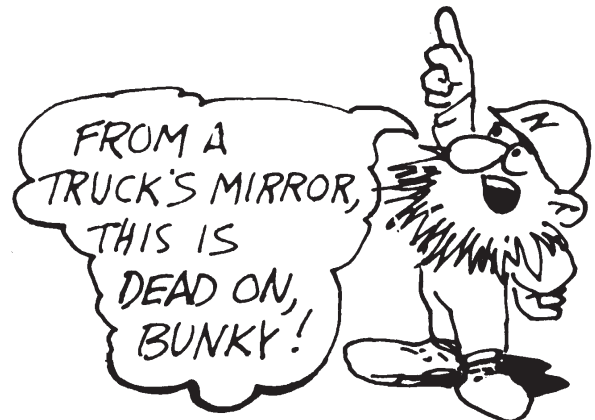
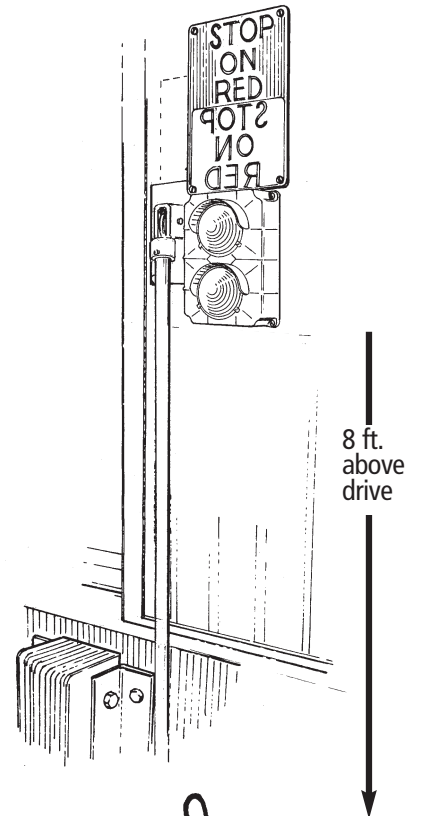
### Figure 14



## Step 16

- Fasten printed sign to outside wall, above light, as shown in Figure 15. "RED" sign should be above light. Attach sign to building with fasteners.

### Figure 13MP



### ⚠ CAUTION

Be sure that installation is performed only by qualified personnel and that electrical hook-up is performed by a qualified electrician.

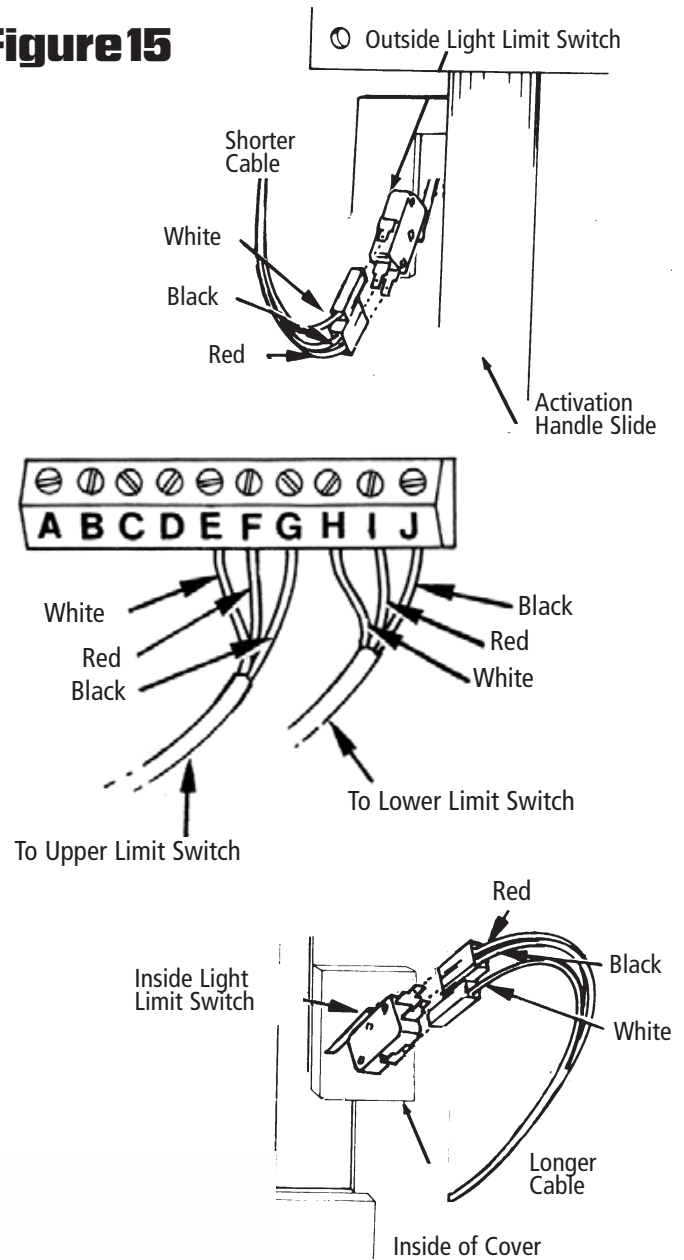
## Step 17M

•Turn console cover around. Connect the (2) three-wire electrical cables from the control box to the limit switches, one mounted on the cover and the other mounted on the top of the slide pole. See Figure 15.

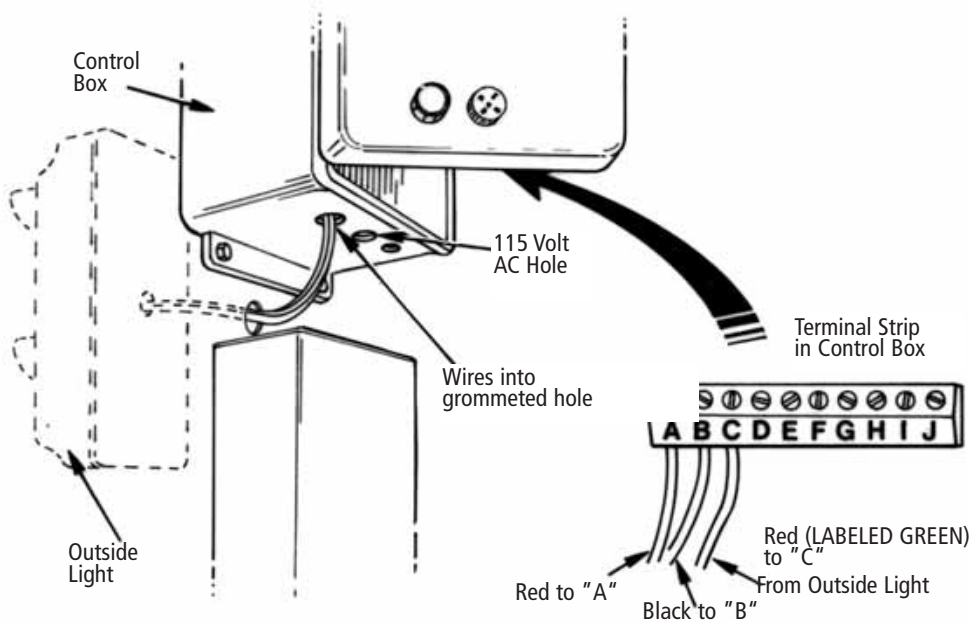
## Step 18

•Route wire from outside light to inside control box through the grommets hole in the bottom of the box. Cut to length and connect to terminal strip as shown in Figure 17.

### Figure 15



### Figure 17



## Step 19M

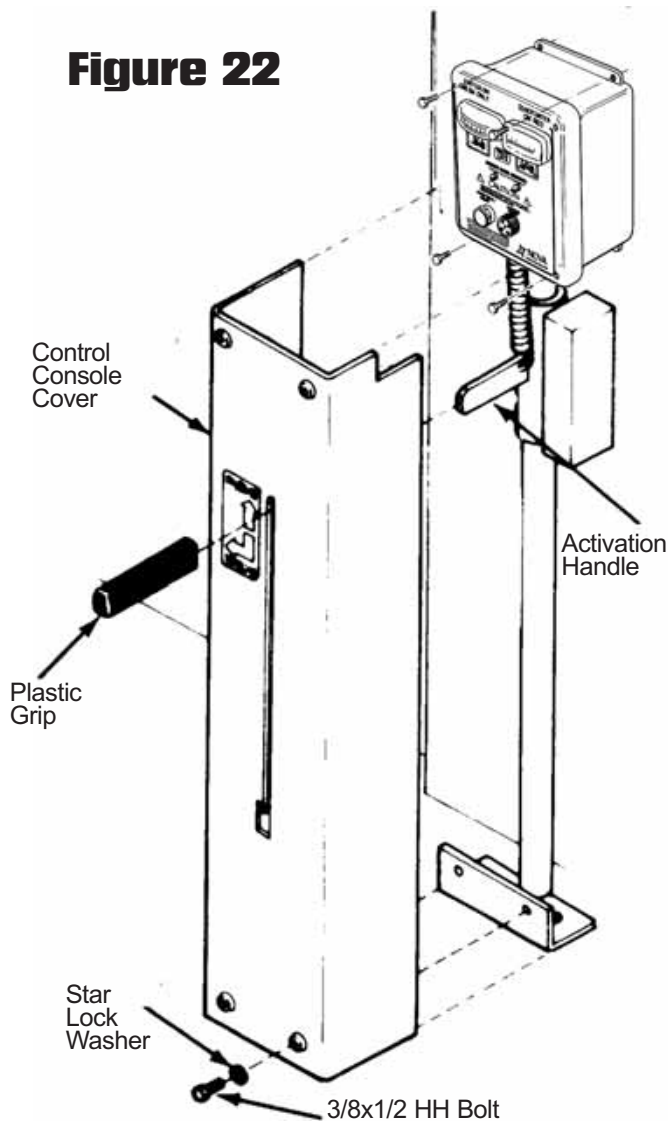
- Insert plug into wall receptical or hard wire per local codes.

## Step 20M

- Replace cover on control console and secure with four 3/8" x 1/2" bolts and star lock washers. Slide plastic grip on to Activation Handle. See Figure 22.

**IMPORTANT:** MAKE SURE THAT WIRES FROM CONTROL BOX WILL NOT GET TANGLED IN ACTIVATION HANDLE, OR COUNTERWEIGHT ASSEMBLY ONCE CONSOLE COVER IS REPLACED

**Figure 22**

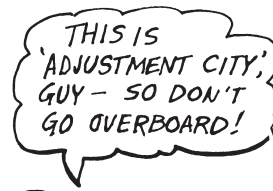


## Step 21M

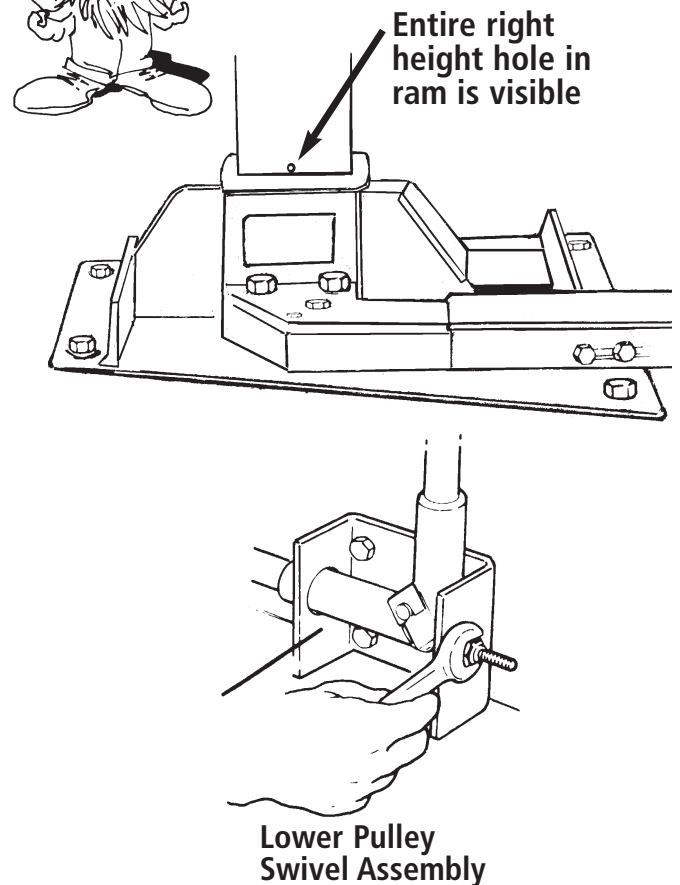
- Move Activation Handle down into "Restrain" position which will raise restraint ram outside. Adjust ram height by turning nut on lower pulley assembly. Tighten cable until entire right height hole in ram is visible above top of ram housing. Do not overtighten as ram will not completely lower when handle is raised. See Figure 23.

## Step 22M

- Test entire restraint operation along with proper light sequence and make adjustments as necessary.



**Figure 23**



**This completes the installation of a typical Manual System — turn to page 21 for important final checks**

# THE FOLLOWING SECTION

PAGES 14-16 OF THIS MANUAL ARE FOR INSTALLATION OF PNEUMATIC TRUCK RESTRAINTS (MODELS 201FP).

## Step 13P

■ Manually extend air cylinder. Run end of cable through pulley at top of cylinder rod, pull cable tight, and attach end to clevis pin at top on control console frame using cable clamp supplied. See Figure 24. Cut off excess cable.

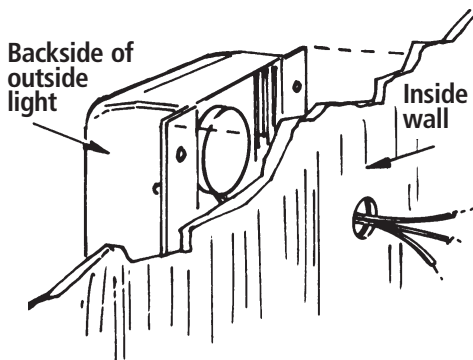
### IMPORTANT

Pull cable only tight enough to remove all slack from cable. Do not pull so tight that you raise the ram from its resting position in the housing.

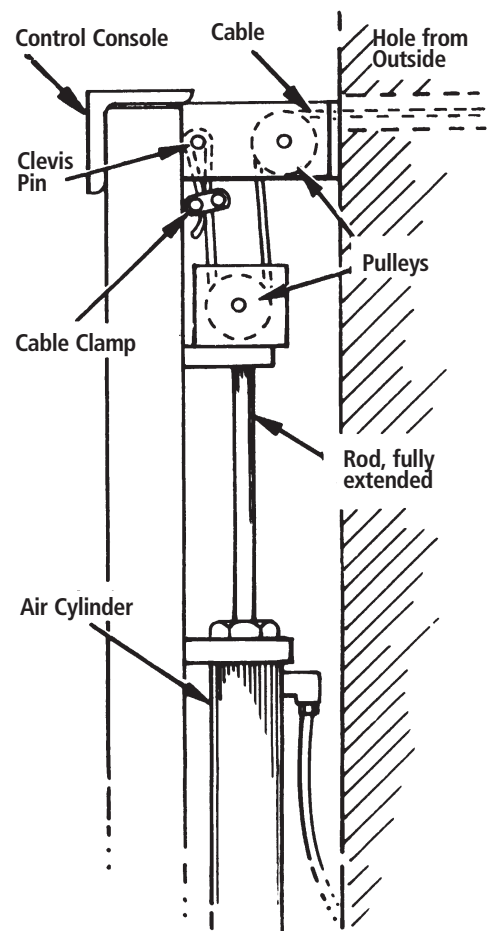
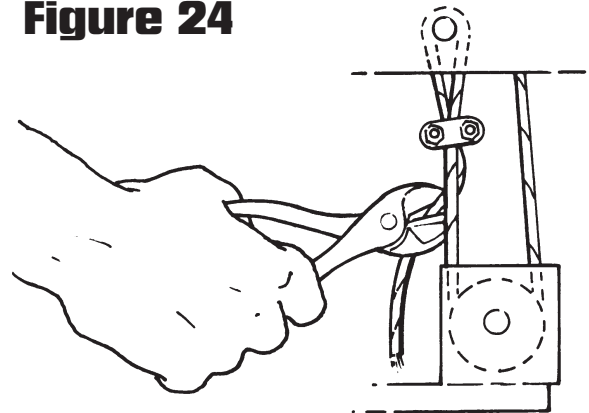
## Step 14P

• Determine location of outside light on exterior of building. Light must be on truck driver side of dock door (right side when facing dock from outside) and 8 ft. above surface of drive. Be sure location of light will not interfere with the future installation of dock shelters or seals. Drill hole through wall at approximate center of light. Feed wire from light through hole in wall and affix light to wall. See Figure 25.

**Figure 25**



**Figure 24**



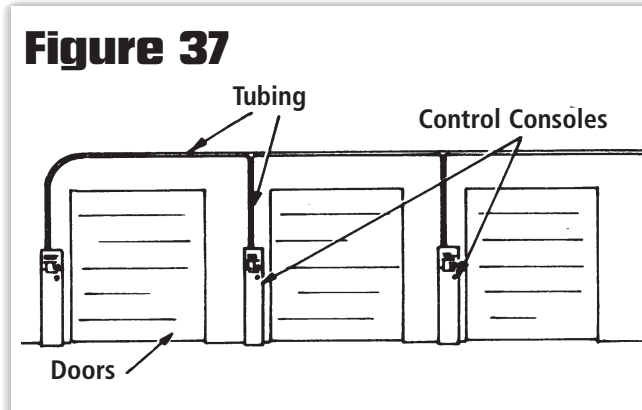
## Step 15P

•Connect the (2) three-wire electrical cables from the control box to the limit switches mounted on the console frame. See Figure 28.

**NOTE:** Purge line prior to hooking up system. Air may be supplied from plant system or by small compressor. Air must be minimum of 100 lbs./square inch and maximum of 130 lbs./square inch. Air must be dry and clean. Air usage is approximately .020 cubic feet per operation. Duration of normal power stroke is about 2 seconds.

## Step 16P

•Run 1/4" polyurethane tubing capable of withstanding 150 psi above dock doors as in Figure 37. Plot the tees to align with the console(s).



## Step 17P

•Run polyurethane tubing from header tee to control valve. Cut polyurethane tubing to allow for cover removal.

## Step 18P

•Connect short tube from control valve to quick connect on air cylinder. See Figure 38.

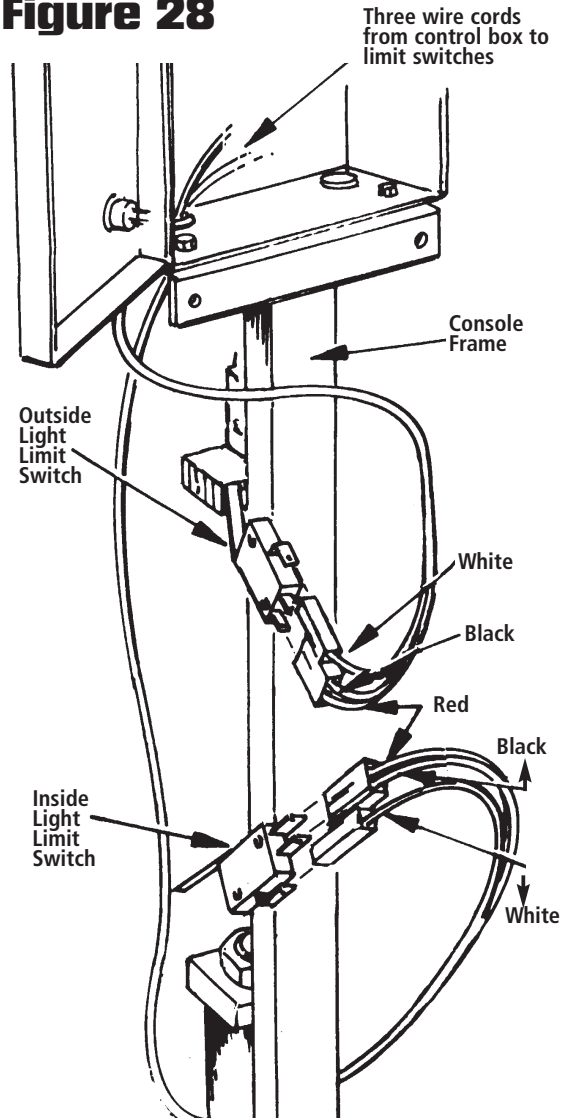
## Step 19P

•Turn air supply on.

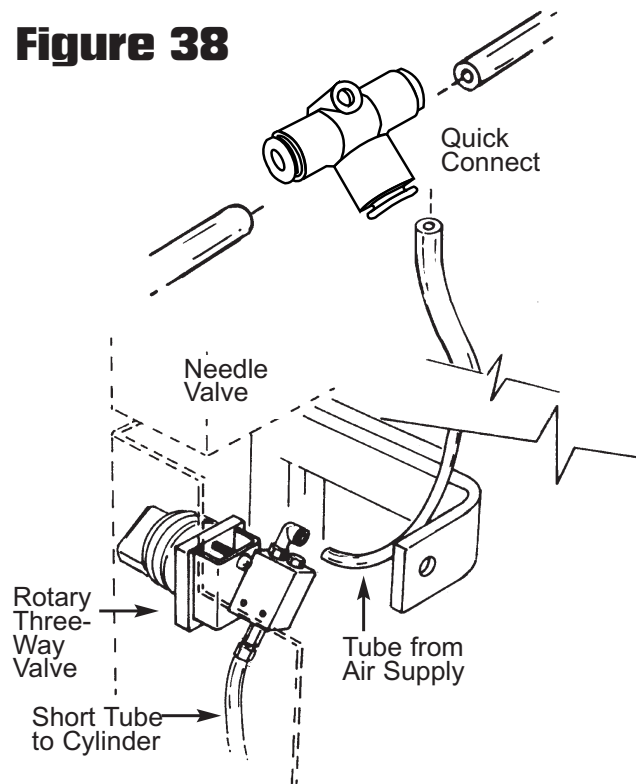
### **CAUTION**

Be sure to keep hands clear of air cylinder, pulley assembly and cable when retracting cylinder. Personal injury could result.

## Figure 28



## Figure 38



## Step 20P

- Replace control console cover and secure with four 3/8" x 1/2" bolts and star lock washers.

## Step 21P

- Move control valve lever to up "RESTRAIN" position.

## Step 22P

- The unit is shipped with the needle valve 4 turns.

## Step 23P

- Move control lever to down and lower ram.

**NOTE:** Lowering speed is not adjustable and is controlled by internal orifice.

## Step 24P

- Cycle unit again. Turn adjusting knob on needle valve out to increase rise speed and in to decrease speed. Continue to cycle unit until desired speed is obtained.

### ⚠ CAUTION

Adjusting needle valve so that ram rises too fast can cause unnecessary stress on the unit and may present danger to personnel or equipment.

**NOTE:** When properly adjusted, the ram should fully rise in 1 to 2 seconds. There should be less than 1/2" of "hop" by the ram at the end of the rise stroke.

## Step 25P

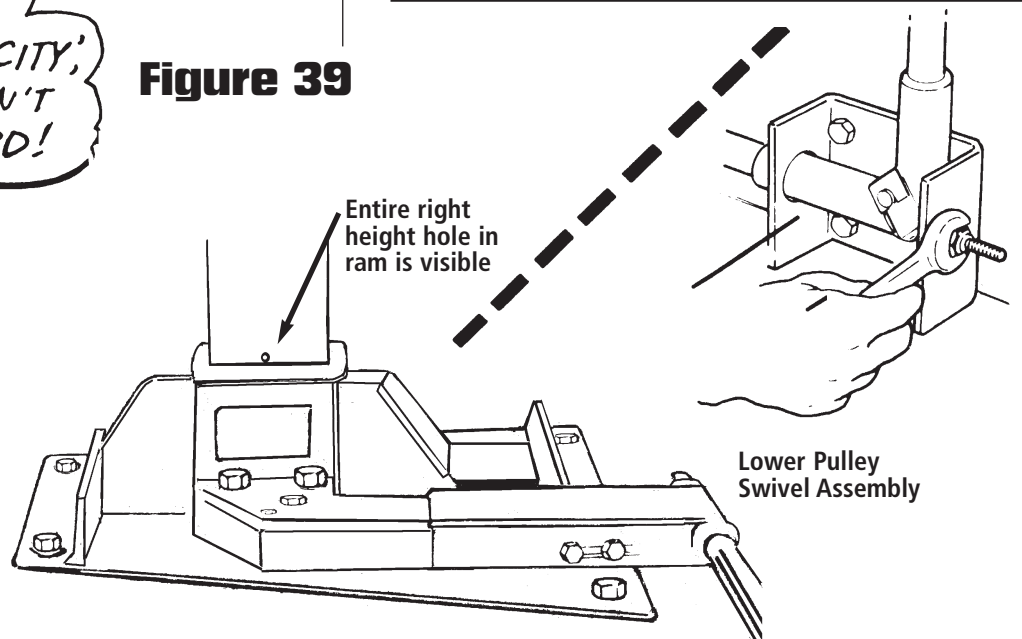
- Move control lever to "RESTRAIN" position. Adjust ram height by turning nut on lower pulley swivel assembly. Tighten cable until right height hole in ram is just visible above top of ram housing. Cycle unit several times to check cable adjustment. See Figure 39.

### ⚠ CAUTION

If Ram does not completely lower, cylinder damage could result and range of Truck Lock will be reduced.

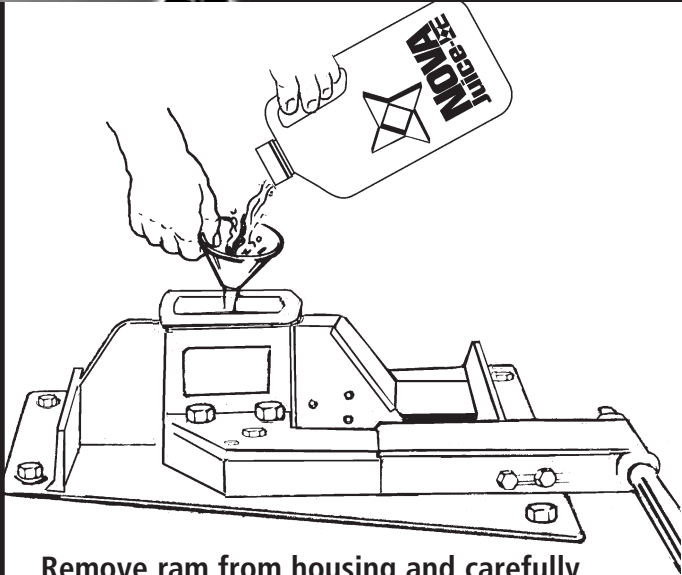


**Figure 39**



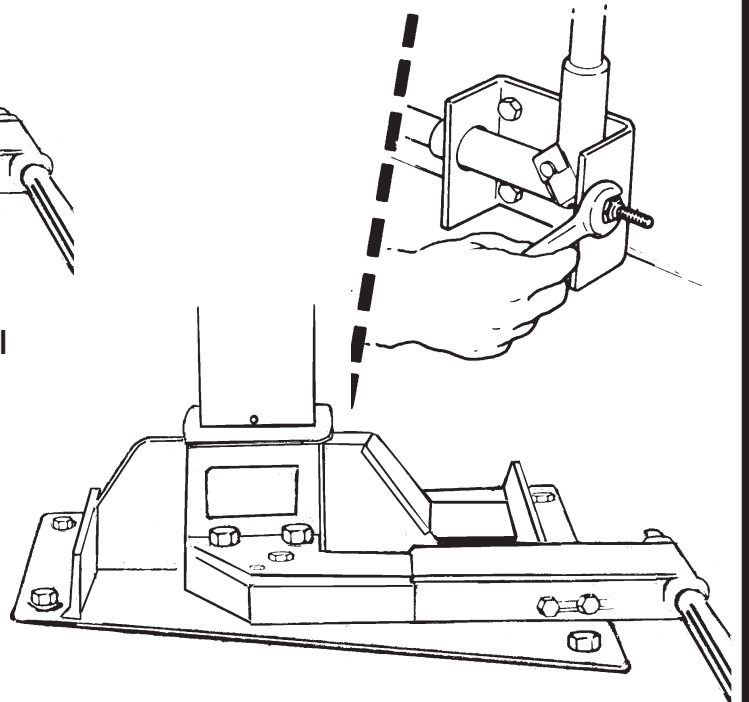
**This completes the installation of a typical Truck Lock System — turn to page 21 for important final checks**

# IMPORTANT CHECKS!



Remove ram from housing and carefully pour in 2 quarts of Nova Juice-E. This prevents freezing and corrosion under normal operating conditions.

Adjust cable length by turning nut on lower pulley assembly. Tighten cable until entire guide height hole in ram is visible above top of ram housing. Do not overtighten as ram will not completely lower when lever is released.



AN' THAT'S IT!  
NOW, LET'S SPRUCE UP THE  
WORK SITE FOR A REAL  
PROFESSIONAL TOUCH—AN'  
GO HOME KNOWIN' WE'VE DONE  
OUR JOBS!!



**This completes the installation. Pack up tools, clean up any installation debris for a professional touch that's appreciated by the customer.**

## Step 1S

•Attach sensor switch housing tube to gusset with tek screws or 1/4-20x1 HH screw.

## Step 2S

•Insert switch and wire through fitting in switch housing tube and attach top with 1/4-28x3/8 BHCS

## Step 3S

•(For 101FM AND 201FP W/SENSOR SWITCH KIT ONLY)

Install 1/2" thinwall conduit to shield sensor switch wire running to control box as shown in Figure 30.

## Step 4S

•(For 101FM AND 201FP W/SENSOR SWITCH KIT ONLY)

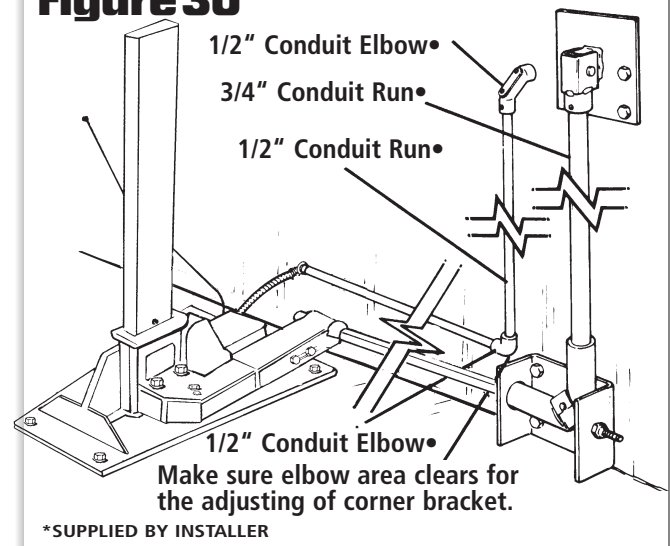
Install truck sensor wand in wand holder. The bend in the wand should face away from the dock wall. Make sure the wand is inserted all the way to the bottom of the hole. Tighten set screw through clearance hole in the side of the housing as shown in Figure 31.

## Step 5S

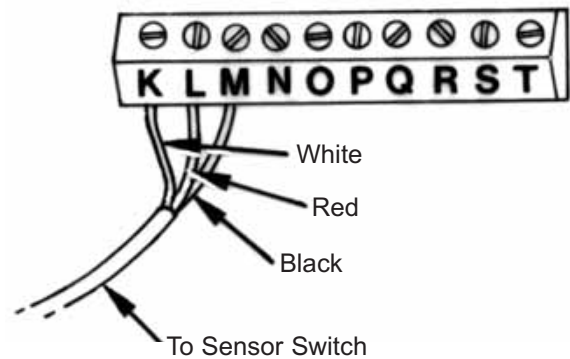
•(For 101FM AND 201FP W/SENSOR SWITCH KIT ONLY)

Uncoil wire from sensor switch and feed through flex conduit, run 3 cond. wire through the 1/2" conduit to control box and it's grommeted hole. Cut wire to length and connect to terminal strip as shown in Figure 32 diagram.

### Figure 30



### Figure 32 Terminal Strip in Control Box

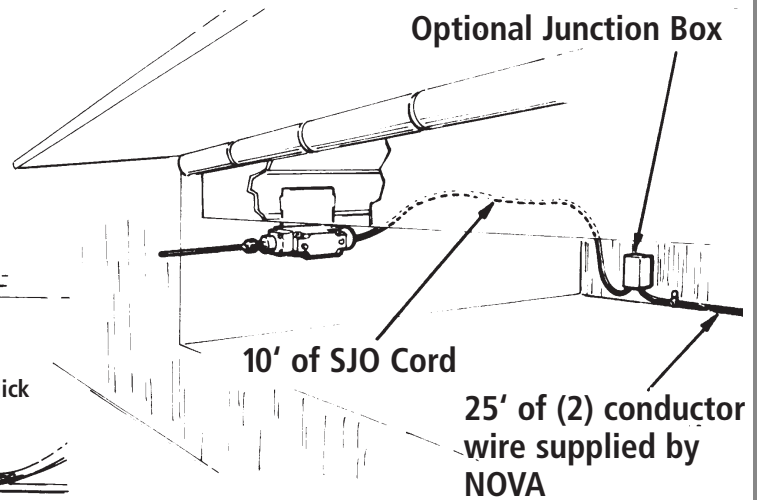
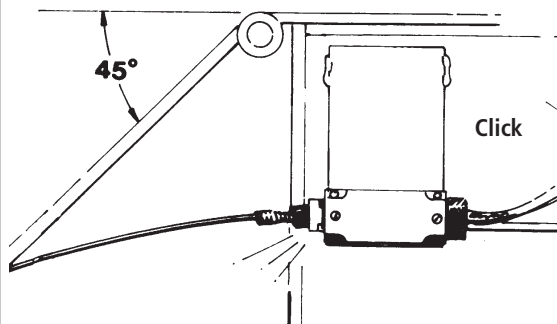


## Steps 11C to 31C applies only to Model 203iFP

If you are not installing interconnect, go to step 15P

### Figure 34

Switch is mounted in such a manner so that when dock lip is at a 45° angle, switch should click and system is activated.



### Step 11C

- Mount the limit switch under the dock board as shown in Figure 34. (Limit switch may also be used in conjunction with the overhead door.)

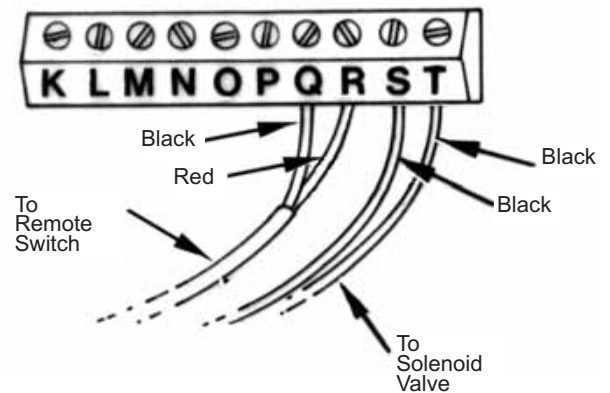
### Step 21C

- Route wire from limit switch into control box through the grommeted hole. Cut the wire to length and connect to the terminal strip as shown in Figure 35. Black to "A", White to "B".

### Step 31C

- Route wire from solenoid valve into control box through the grommeted hole. Cut the wire to length and connect to the terminal strip as shown in Figure 35. Black to "D", Black to "E". (Either black wire in either position will work.)

### Figure 35



# GENERAL MAINTENANCE

## ! WARNING

Be sure that main power to unit is locked out and tagged according to OSHA regulations and local codes prior to performing any maintenance or repair!

### Daily

- Operate the TRUCK LOCK to assure it is in proper working condition. Replace damaged or missing light bulbs and lenses.

### Every 180 Days

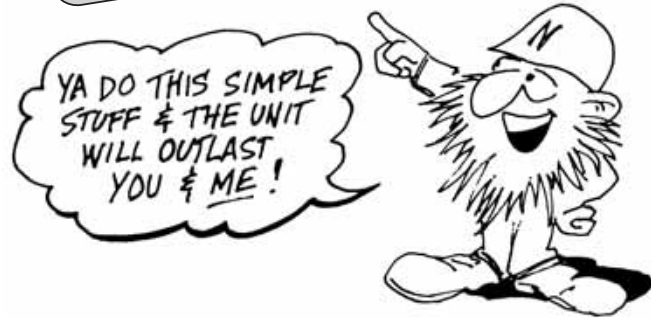
- Apply grease to slide pole or cylinder pole.
- Check and tighten concrete anchors to a torque of 70-75 ft-lbs.
- Inspect slab around restraint for any cracks or imperfections.

### Annually

- **ALL MODELS.** For best performance, remove old, used fluids (siphon, drill pump, shop vac) and replace with new mixture. Replace all outside light bulbs.



Nova Technology requires NOVA Juice-E to be used on all new truck restraints. Failure to follow instructions will result in a voided warranty.



# ELECTRICAL TROUBLESHOOTING

• **NOTE:** In case of electrical malfunction, refer to electrical trouble shooting guide as well as the wiring diagram.

## ! WARNING

Be sure that the main power to the unit is locked out and tagged according to OSHA regulations and local codes prior to performing any electrical work. Electrical troubleshooting and repair should be performed only by a qualified electrician.

### Light Functions and Related Components

#### LIGHT MALFUNCTION RELATED COMPONENTS

All	115V power to unit, fuse, transformer, upper and lower limit switch.
Outside Red	Bulb, upper limit switch.
Outside Green	Bulb, upper limit switch.
Both Outside Lights	Common lead to lights, upper limit switch.
Inside Red (Flashing)	Bulb, lower limit switch.
Inside Red (Constant)	Bulb, lower limit switch.

#### LIGHT MALFUNCTION RELATED COMPONENTS

Inside Green	Bulb, lower limit switch.
Blue (Flashing)	L.E.D., lower limit switch, sensor switch.
Blue (Constant)	L.E.D., lower limit switch, sensor switch.
All Inside Lights	Common lead to lights (cover), lower limit switch.
Inside Red L.E.D.	Outside red or outside
Inside Green L.E.D.	green bulb, L.E.D. bulb.

### Electrical Component Check

#### COMPONENT

#### CHECK

Fuse	Visual and continuity.
Printed Circuit Board	Visual check L.E.D. on Board.

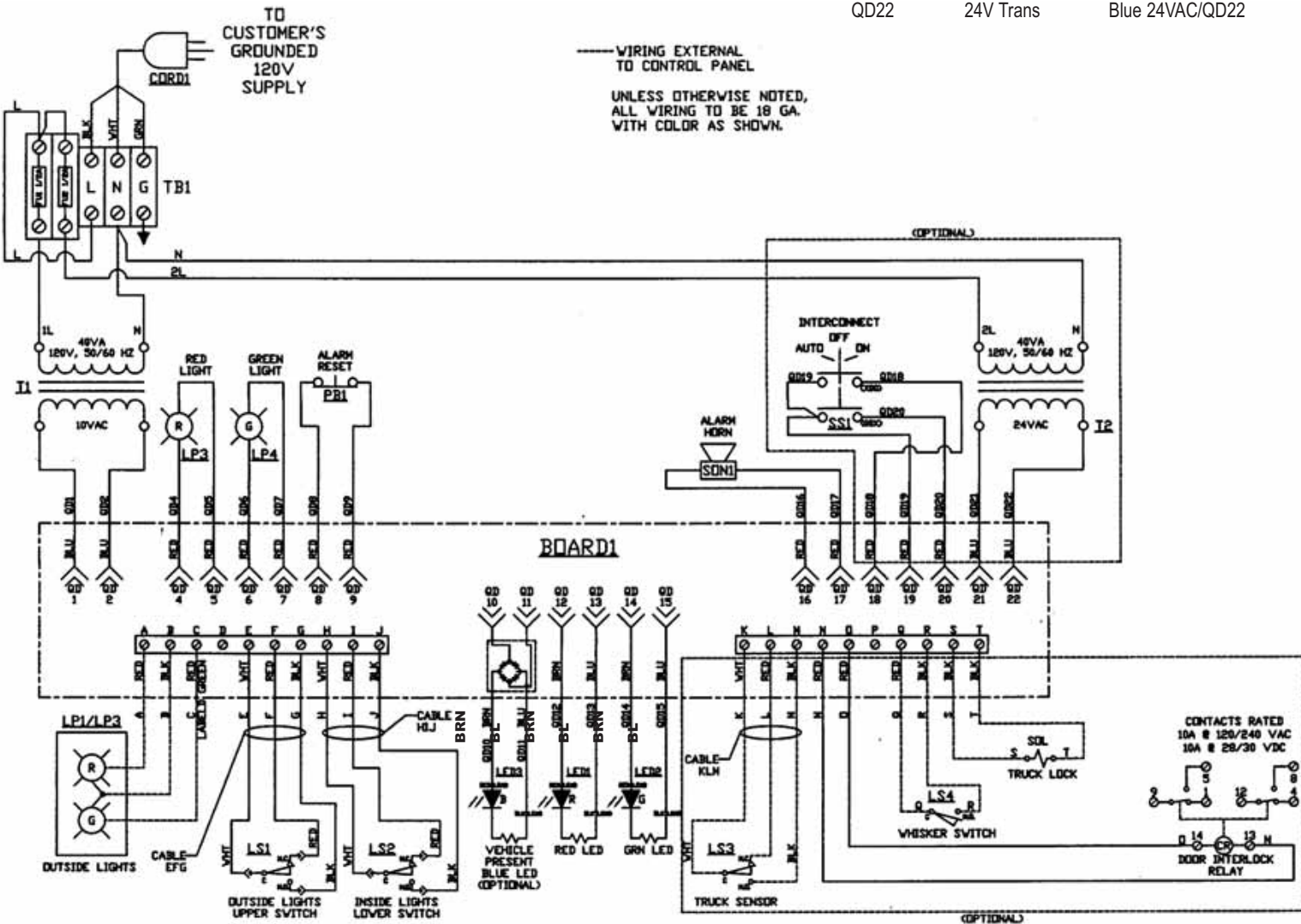
#### COMPONENT

#### CHECK

Transformer	Disconnect and check primary continuity and secondary continuity.
Limit Switches	Disconnect and check continuity. common/ normally open, common/normally closed

# Truck Lock™ 351 Series Electrical Schematic

Term	Component	Wire Color	QD	Component	Wire Color / #
A	Outside Light	Red	QD1	10V Trans	Blue 10VAC/QD1
B	Outside Light	Black	QD2	10V Trans	Blue 10VAC/QD2
C	Outside Light	Red- Labeled Green	QD3		
D			QD4	Red Light	Red/QD4
E	Outside Limit Switch- Upper	White	QD5	Red Light	Red/QD5
F	Outside Limit Switch- Upper	Red	QD6	Green Light	Red/QD6
G	Outside Limit Switch- Upper	Black	QD7	Green Light	Red/QD7
H	Inside Limit Switch-Lower	White	QD8	Alarm Reset	Red/QD8
I	Inside Limit Switch-Lower	Red	QD9	Alarm Reset	Red/QD9
J	Inside Limit Switch-Lower	Black	QD10	Blue LED	Brn/QD10
K	Sensor Switch	White	QD11	Blue LED	Bl/Wh/QD11
L	Sensor Switch	Red	QD12	Red LED	Brn/QD12
M	Sensor Switch	Black	QD13	Red LED	Blue/QD13
N	Interlock Relay	Red	QD14	Green LED	Brn/QD14
O	Interlock Relay	Red	QD15	Green LED	Blue/QD15
P					
Q	Remote Switch	Red	QD16	Sounder	Red/QD16
R	Remote Switch	Black	QD17	Sounder	Red/QD17
S	Solenoid Valve	Black	QD18	Selector Switch	Red/QD18
T	Solenoid Valve	Black	QD19	Selector Switch	Red/QD19
			QD20	Selector Switch	Red/QD20
			QD21	24V Trans	Blue 24VAC/QD21
			QD22	24V Trans	Blue 24VAC/QD22



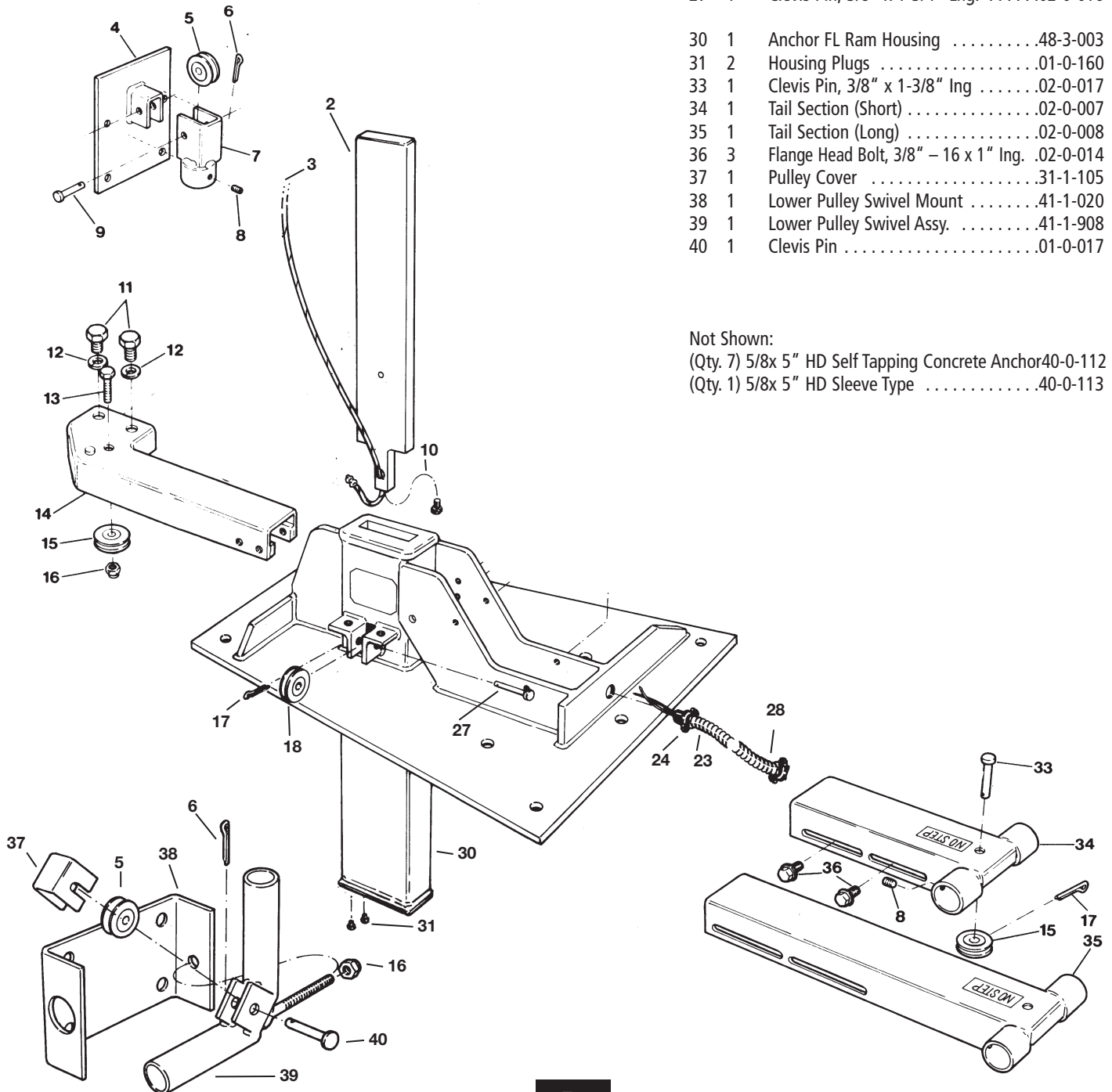
# Anchor Flange Series Ram & Ram Housing Assembly

## Models 100FM, 101FM, 201FP

ITEM	REQ.	DESCRIPTION	PART NO.
2	1	Ram Assembly	.02-0-002
3	1	Cable, 25 ft.	.03-0-001
4	1	Upper Pulley Swivel Brkt.	.41-1-912
5	2	Pulley	.03-0-002
6	2	Cotter Pin, 1/16" x 3/4"	.01-0-082
7	1	Swivel Cap	.41-1-902
8	2	Socket Set Screw 1/4" - 20 x 1/4"	.01-0-007
9	1	Clevis Pin, Long	.01-0-083

ITEM	REQ.	DESCRIPTION	PART NO.
10	1	Ram Plug	.02-0-010
11	2	Hex Hd. Bolt, SS 5/8" - 11 x 1"	.02-0-011
12	2	Lockwasher, 5/8"	.02-0-012
13	1	Hex Hd. Bolt, 3/8" - 16 x 1-1/4"	.02-0-013
14	1	Anchor Side Extension	.02-0-009
15	2	Pulley, 1-3/4" dia.	.03-0-003
16	2	Hex Nut, 3/8" - 16 Nyllok	.01-0-016
17	2	Cotter Pin, 1/8" x 3/4"	.01-0-012
18	1	Pulley, 2" dia.	.03-0-004

27	1	Clevis Pin, 3/8" x 1-3/4" Lng.	.02-0-016
30	1	Anchor FL Ram Housing	.48-3-003
31	2	Housing Plugs	.01-0-160
33	1	Clevis Pin, 3/8" x 1-3/8" Lng	.02-0-017
34	1	Tail Section (Short)	.02-0-007
35	1	Tail Section (Long)	.02-0-008
36	3	Flange Head Bolt, 3/8" - 16 x 1" Lng.	.02-0-014
37	1	Pulley Cover	.31-1-105
38	1	Lower Pulley Swivel Mount	.41-1-020
39	1	Lower Pulley Swivel Assy.	.41-1-908
40	1	Clevis Pin	.01-0-017



Not Shown:  
 (Qty. 7) 5/8x 5" HD Self Tapping Concrete Anchor 40-0-112  
 (Qty. 1) 5/8x 5" HD Sleeve Type 40-0-113

# CONTROL BOX ASSEMBLY

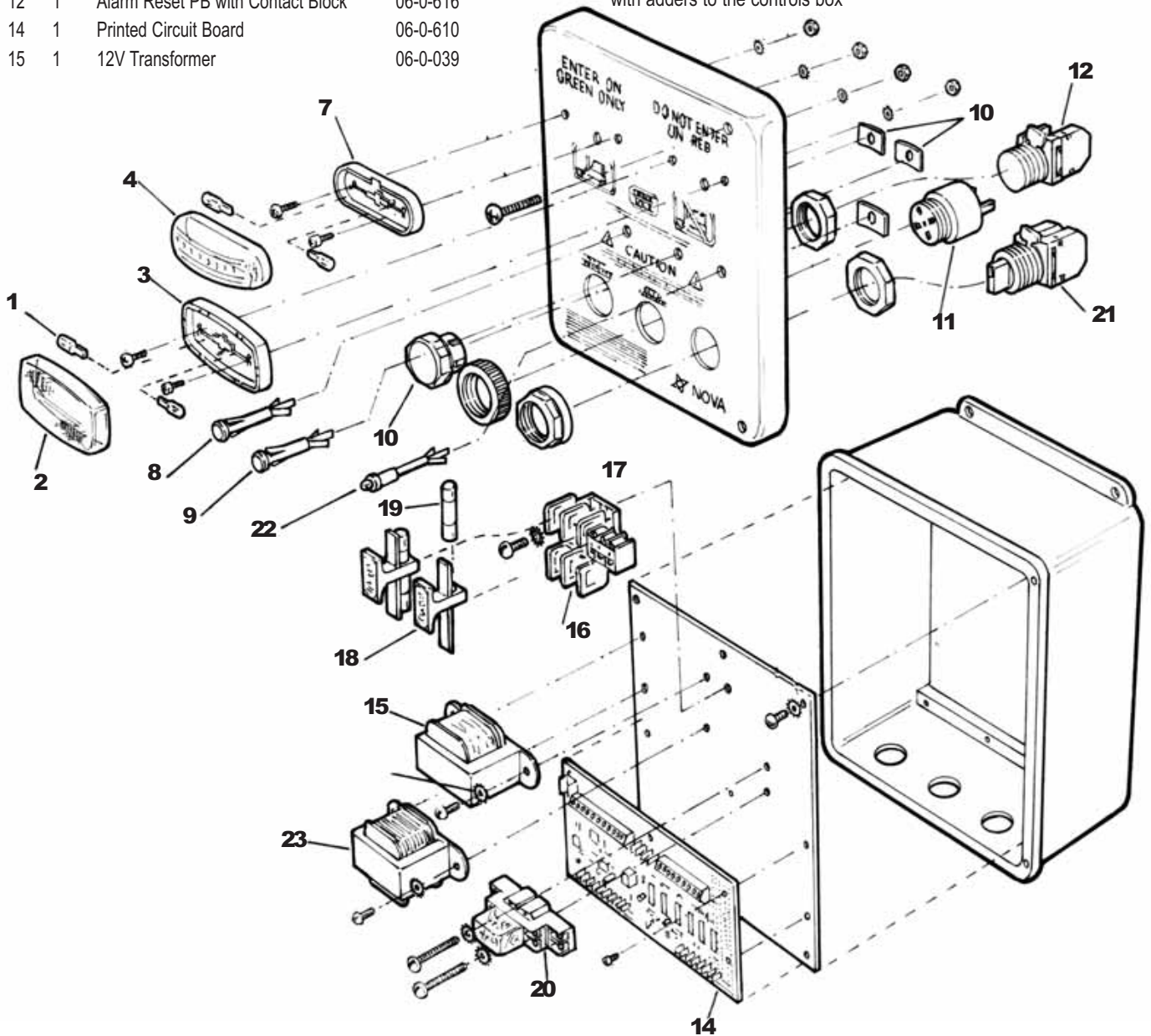
## Models 101FM, 201FP

### Control Box Assembly

ITEMREQ.	DESCRIPTION	PART NO.
1	4 Incandescent Bulb	06-0-048
2	1 Red Lens Only	06-0-602
3	1 Red Light Assembly	06-0-601
4	1 Green Lens Only	06-0-008
7	1 Green Light Assembly	06-0-006
8	1 LED Indicator, Red	06-0-611
9	1 LED Indicator, Green	06-0-612
10	2,1 LED holding Clip	06-0-613
11	1 Alarm horn with contact Block	06-0-615
12	1 Alarm Reset PB with Contact Block	06-0-616
14	1 Printed Circuit Board	06-0-610
15	1 12V Transformer	06-0-039

ITEMREQ.	DESCRIPTION	PART NO.
16	1 Terminal Block 3 Pole	06-0-605
17	1,1 Fuse Block	06-0-603
18	1,1 Fuse Puller	06-0-604
19	1,1 1/2 Amp Fuse	06-0-606
20	1 Relay 12VDC, 2PDT with Socket	06-0-608
21	1 3 Position Selector Switch	06-0-631
22	1 LED Indicator, Blue	06-0-651
22	1 LED Indicator, Blue	06-0-651
23	1 24V Transformer	06-0-040

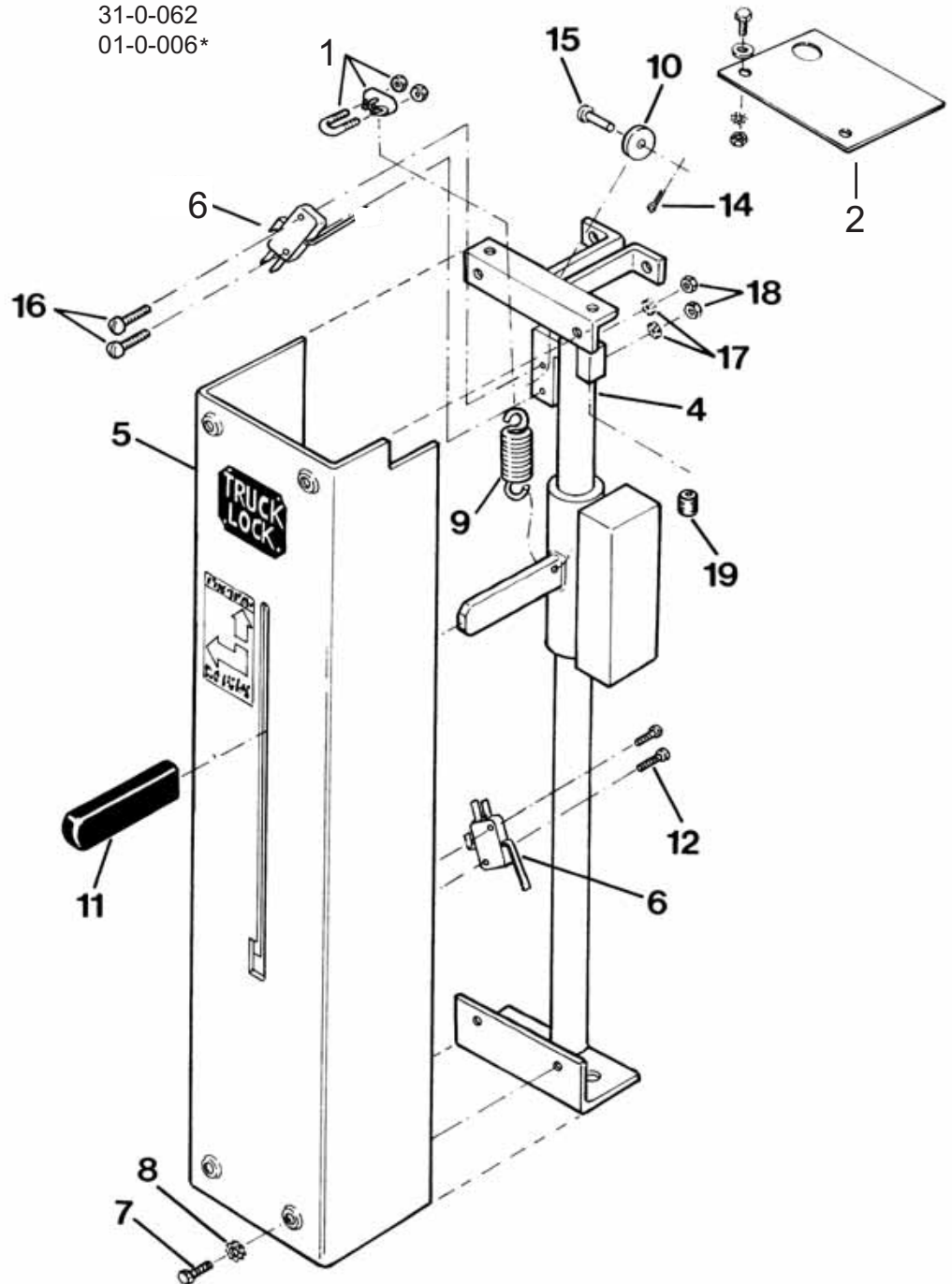
Items 20, 21, 22, & 23 are available with adders to the control box  
 Items 10, 17, 18, 19 have the extra quantity listed with adders to the controls box



# CONSOLE ASSEMBLY

## 350FM and 351FM Console Assembly

ITEM	QTY	DESCRIPTION	PART NUMBER	ITEM	QTY	DESCRIPTION	PART NUMBER
1	1	Cable Clamp	03-0-007	13	1	Cotter Pin 1/8 x 3/4	01-0-012
2	1	Remote Box Cover Plate	41-1-018	14	1	Clevis Pin 3/8 x 1-3/8	01-0-017
4	1	2" Slide Pole Ass'y	31-3-917	15	2	Round Head Screw #4-40x1	01-0-096*
5	1	Manual Cover Ass'y	31-3-908	16	2	Star Lock Washer #4	01-0-097*
6	2	Limit Switch	06-0-013*	17	2	Hex Nut #4-40	01-0-098*
7	4	Hex Head Bolt 3/8-16 x 1/2	01-0-001	18	1	Dampener	31-1-031
8	4	Star Lock Washer 3/8	01-0-002	*Are sold with 351M only			
9	1	Extension Spring	31-0-202	Items 4 and 5 are sold as assemblies only			
10	1	Pulley 2"	03-0-004				
11	1	Handel Cover	31-0-062				
12	2	Round Head Screw #4-40x1/2	01-0-006*				



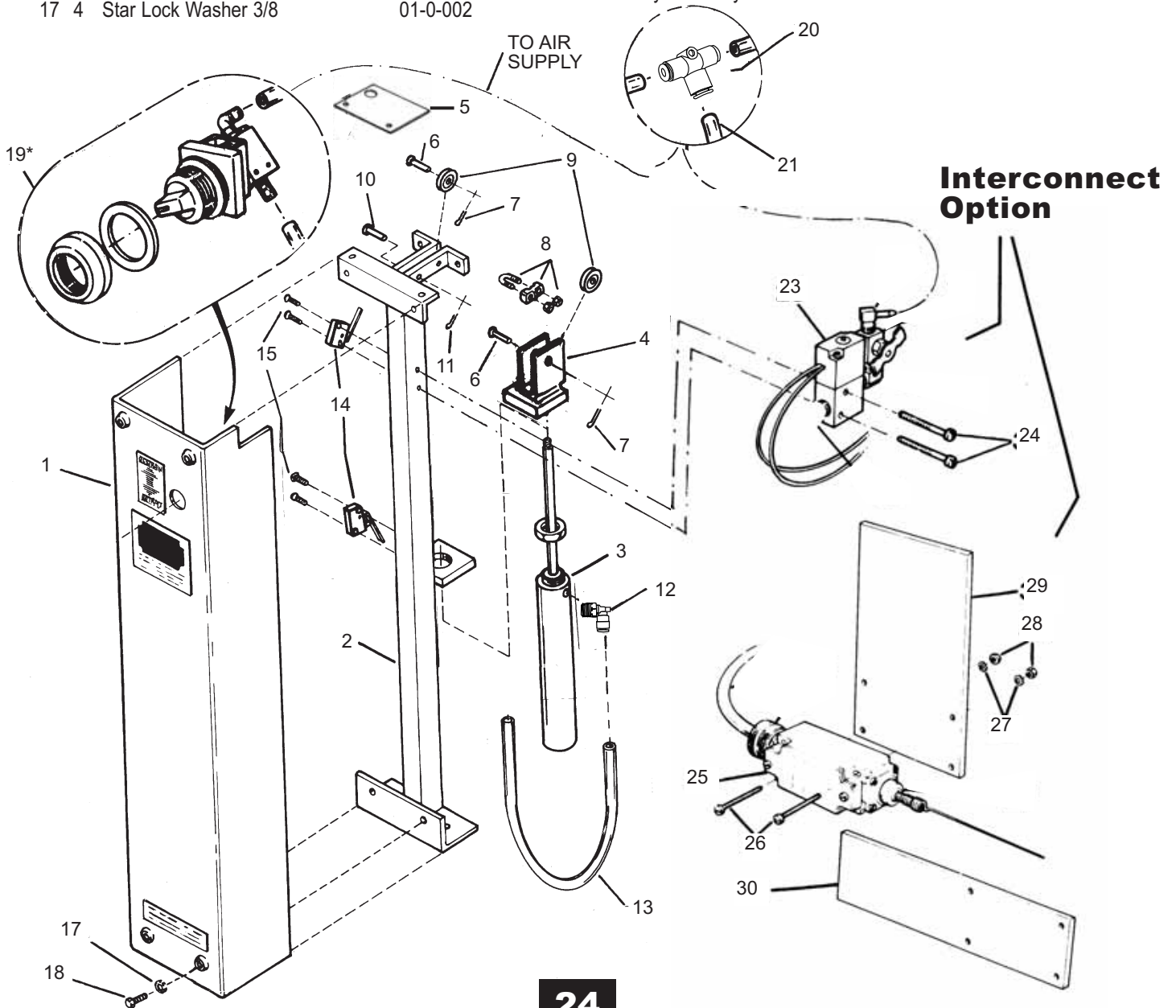
# 351FP CONSOLE ASSEMBLY

## 351P and Interconnect Option Console Assembly

ITEM	QTY	DESCRIPTION	PART NUMBER
1	1	P Console Cover Ass'y	31-3-310
2	1	2" Universal Cylinder Ass'y	02-3-036
3	1	10" Air Cylinder Ass'y	07-3-013
4	1	2" Rod End Ass'y	31-3-924
5	1	Remote Box Cover Plate	41-1-018
6	2	Clevis Pin 3/8 x 1-3/8	02-0-017
7	2	Cotter Pin 1/8 x3/4	01-0-012
8	1	Cable Clamp	03-0-007
9	1	Pulley 2"	03-0-004
10	1	Clevis Pin 1/4 x 1-1/4	01-0-083
11	1	Cotter Pin 1/16 x3/4	01-0-082
12	1	90 Deg Flow Control	07-0-135
13	1	26" Airline	07-0-007
14	2	Limit Switch	06-0-013
15	4	Round Head Screw #4-40x1/2	01-0-006
17	4	Star Lock Washer 3/8	01-0-002

ITEM	QTY	DESCRIPTION	PART NUMBER
18	4	Hex Head Bolt 3/8-16 x1/2	01-0-001
19	1	Rotary Valve Ass'y	07-3-130*
20	1	Union Tee	07-0-017
21	1	25 Ft Airline	07-0-008
23	1	Solenoid Valve Ass'y	07-3-045
24	2	Screw #6-32 x 1	01-0-010
25	1	Remote Limit Switch	06-0-047
26	2	RH Screw 10-24 x 1-1/2	01-0-133
27	2	Lock Washer #10	01-0-131
28	2	Hex Nut #10-24	01-0-132
29	1	Vertical Mount Plate Door	40-1-005
30	1	Horiz. Mount Plate Leveler	40-1-004

Items 1, 2, 3, 4, 19 are sold as assemblies only  
 Items 23-30 are for interconnect options only  
 Keyed Rotary Valve Also Available



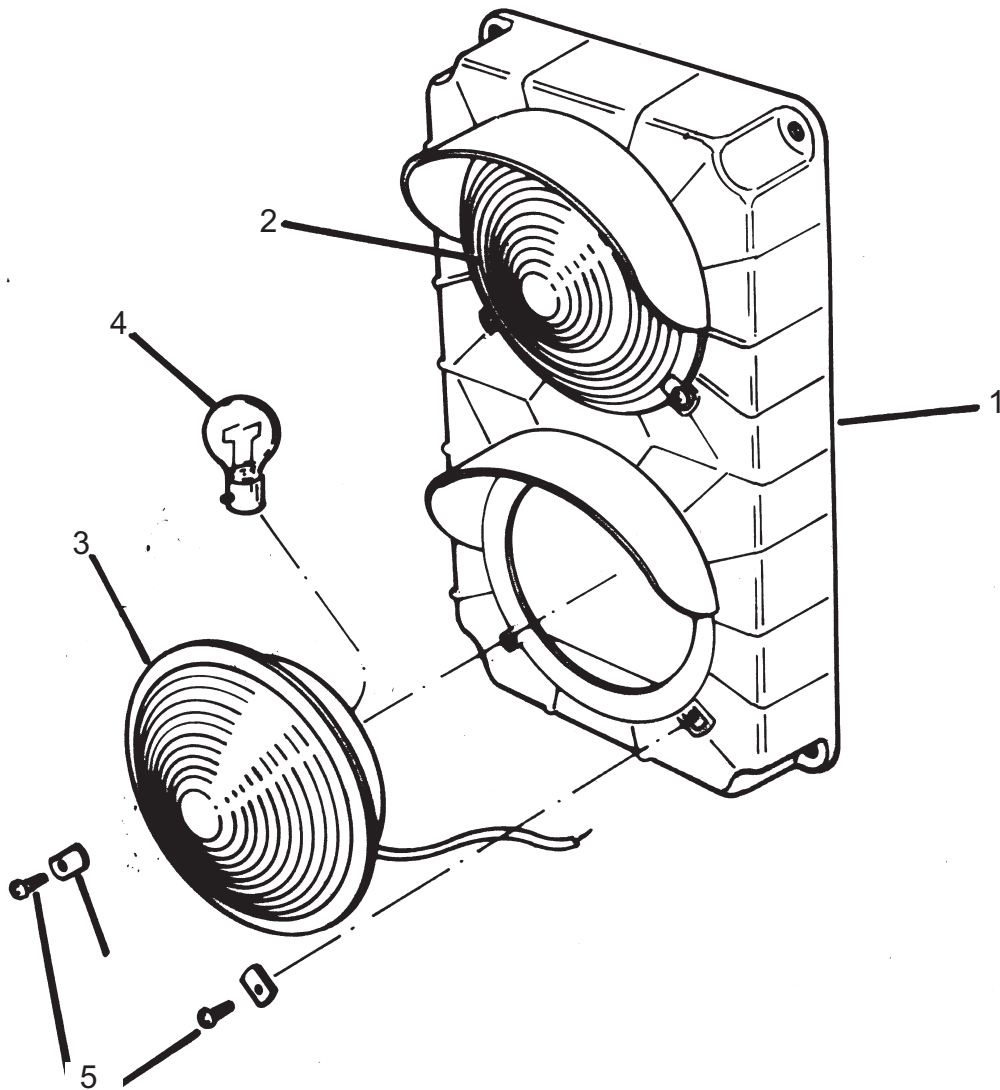
# OUTSIDE LIGHT ASSEMBLY

All Models — except 350FM

ITEM	QTY	DESCRIPTION	PART NUMBER
1	1	Stop & Go Signal Light	06-0-700
2	1	Red Lens with Housing	06-0-721
3	1	Green Lens with Housing	06-0-722
4	2	Outside Light Bulb (1156)	06-0-021
5	4	Screw and Clips	06-0-725

Outside Sign, Stop/Red

NT-0-106







# **NOVA TECHNOLOGY INTERNATIONAL, LLC.**

## **NOVA ANCHOR TRUCK LOCK FLANGE SERIES MANUAL**

©2002 NOVA TECHNOLOGY INT'L, LLC.  
N90 W14507 Commerce Drive, Menomonee Falls WI 53051  
Phone: 262-502-1591. Toll Free: 800-236-7325. Fax: 262-502-1511  
[www.novalocks.com](http://www.novalocks.com)  
NOVA TRUCK LOCK & LOGOS ARE TRADEMARKS  
OF NOVA TECHNOLOGY INT'L, LLC. All Rights Reserved.





## **NOVA ANCHOR TRUCK LOCK FLANGE SERIES MANUAL**

©2002 NOVA TECHNOLOGY INT'L, LLC.

NOVA Technology Int'l, LLC • N90 W14507 Commerce Drive, Menomonee Falls WI 53051

Phone: 262-502-1591. Toll Free: 800-236-7325. Fax: 262-502-1511. [www.novalocks.com](http://www.novalocks.com)

NOVA TRUCK LOCK & LOGOS ARE TRADEMARKS OF  
NOVA TECHNOLOGY INT'L, LLC. All Rights Reserved.